

# HENRY L GALSON

*By EurIng Brian Roberts, CIBSE Heritage Group*



Henry L Galson, 1900-1963

Henry Galson was born in 1900 in Vienna, Austria. At the age of 17, Galson was conscripted into the Austrian Army and appointed as a commissioned officer, being sent to Russia to escort back a company of Russian prisoners. Then he was posted to the Italian front, but the war ended before he saw action.

Galson attended the Vienna Technische Hochschule where he graduated as a mechanical engineer at the age of 22. Austria was in the grip of hyperinflation and “Carlson’s first job as a engineer was in a bread factory, where he became keenly aware that a suitcase full of money could be inadequate for the purchase of a load of bread.” So he immigrated to America.

His first job was as a project engineer at Procter & Schwartz in Philadelphia, a manufacturer of industrial drying and processing equipment. While there he enrolled in a graduate course in Business Administration at Temple University and filed for his first patent for an improved drying system. In 1925, he joined the Bentz Engineering Corporation in Newark, New Jersey thus beginning his involvement in air conditioning. He went on to join the Cooling & Air Conditioning Corporation of New York in 1926, moving on in 1928 to become Chief Engineer of the Philadelphia Drying Machinery Company. The company failed in 1931, at the start of the Great Depression, and Galson was out of work for a year. However, in the nine months before that happened, Galson filed for 5 patents.

He then found employment with the Baldwin Southwark Corporation, a major manufacturer of steam engines, who had recently purchased the refrigeration company of De La Vergne, determined to build up a capability in air conditioning and refrigeration. Baldwin Southwark had two markets in mind: the air conditioning of railway passenger coaches and the possible mass market for a room cooler. In 1932, Galson worked on the latter project for De La Vergne and quickly established the outline design for a self-contained, air-cooled air conditioning unit. Later that year, he filed the basic patent for the “De La Vergne” unit, which became commercially available in 1933. (The unit had a cooling capacity of 14,000 Btu/hr with a 1.5 hp hermetic compressor using the newly introduced R-12. It also had reverse-cycle capability allowing operation in heat pump mode). Galson and his co-contributors were awarded the prestigious John Scott Medal by the City of Philadelphia for “the most meritorious devices for the improvement of the health and comfort of the human race.” Galson continued to make design improvements relating to condensate draining and removal and vibration isolation, but sales were slow and failed to create the mass market originally envisaged. This led to Baldwin Southwark’s decision to concentrate solely on its core market. So in 1937, they sold their air conditioning patents to a consortium of five companies: General Electric, Westinghouse, Frigidaire, Carrier and Sturtevant. Galson was again out of a job, but found employment with Carrier Corporation, then relocating to Syracuse, New York.

His first patents for Carrier were for a room humidifier and then a ceiling-hung humidifier for textile plants. With the advent of World War II, the production of air conditioning equipment declined sharply, but Galson designed a lightweight self-contained air conditioning unit for the Army Air Force. Beginning in 1942, he became engaged in a completely different project –the *Hedgehog* anti-submarine device invented by the British, which fired 24 projectiles in a fixed pattern. Galson simplified the design and its production. At the war’s end, the *Hedgehog* was credited with sinking some 300 submarines.

At Carrier, Galson went on to develop an adsorption type (rotating drum) dehumidifier and the first post-war window type air conditioner, but when a management shake-up took place he again lost his job. So in 1946, Galson formed his own consultancy and designed specialised air conditioning equipment and systems. In the period 1946-47, he designed a window air conditioning unit for Fedders and this proved to be an immediate commercial success. He went on to design refrigeration units for vending machines and a “spot-cooler.”

From 1948 until 1956, Galson served as a consultant to the United States Air Conditioning Corporation and designed an extended range of window units, but the company was too ambitious and went out of business. During the 1950’s, he designed units for the Rheem Corporation and the Mitchell Corporation. A 1953 market survey concluded the planned production of US air conditioning companies was over 1.2 million units with 43% of Galson’s design (by Fedders, Mitchell & Carrier).

Galson remained active in his consulting firm until his death in 1963. In 2005, Henry L Galson was inducted into the ASHRAE Hall of Fame.

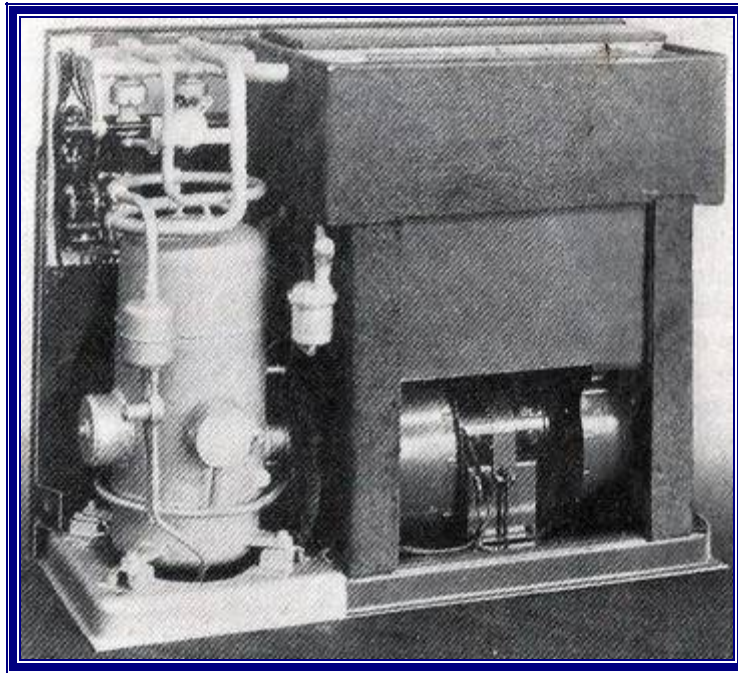

**Early De La Vergne air conditioning unit, about 1932**

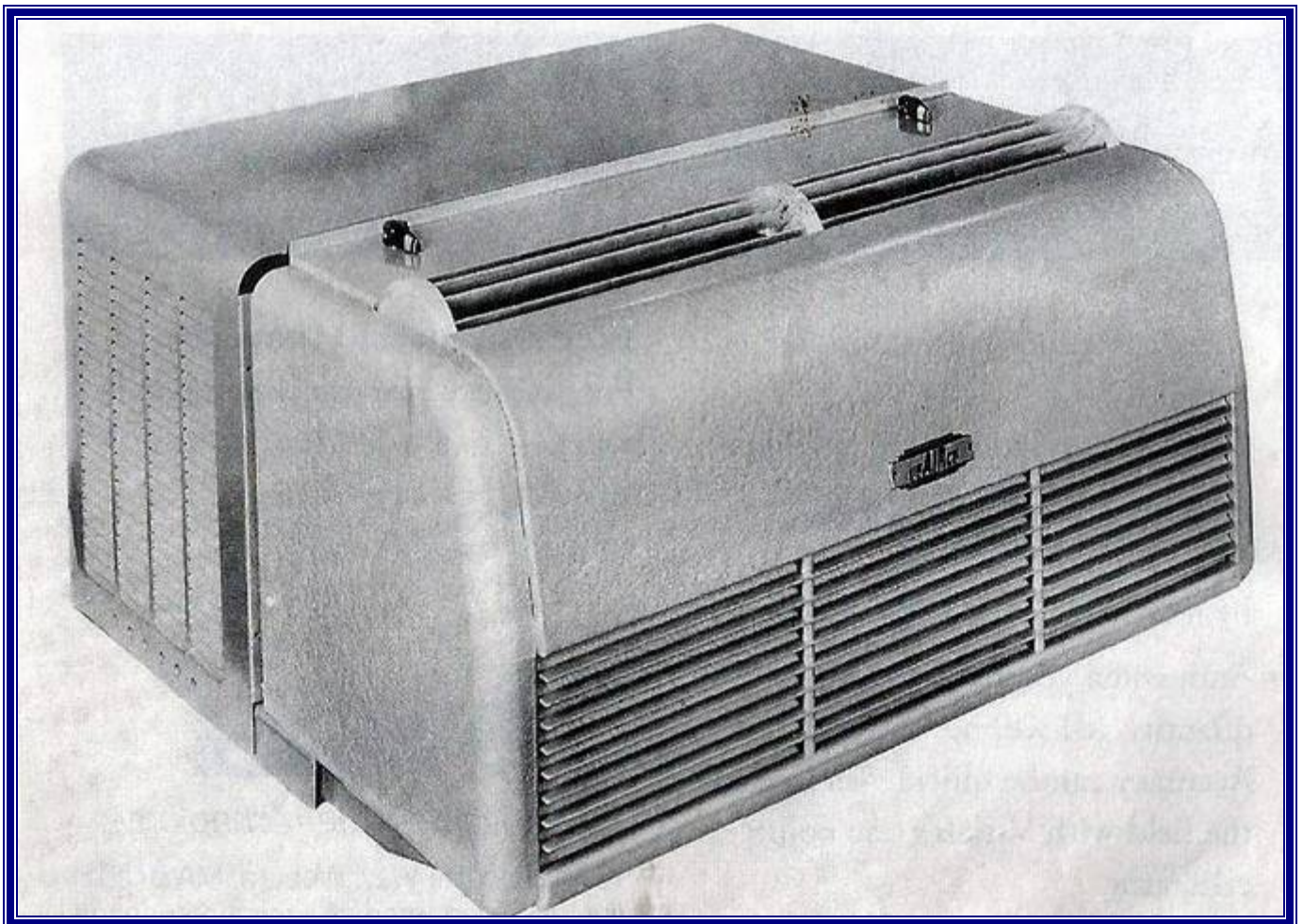

**Window air conditioning unit by US Air Conditioning Corporation, c.1950**



De La Vergne room air conditioning unit, mid-1930s

Sept. 1, 1936.

H. L. GALSON

2,052,561

MEANS FOR INTERCHANGING COMPRESSOR AND CONDENSER FUNCTIONS OF  
A REFRIGERATING SYSTEM AND CONTROLLING A COMPRESSOR THEREFOR

Filed May 31, 1933

2 Sheets-Sheet 1

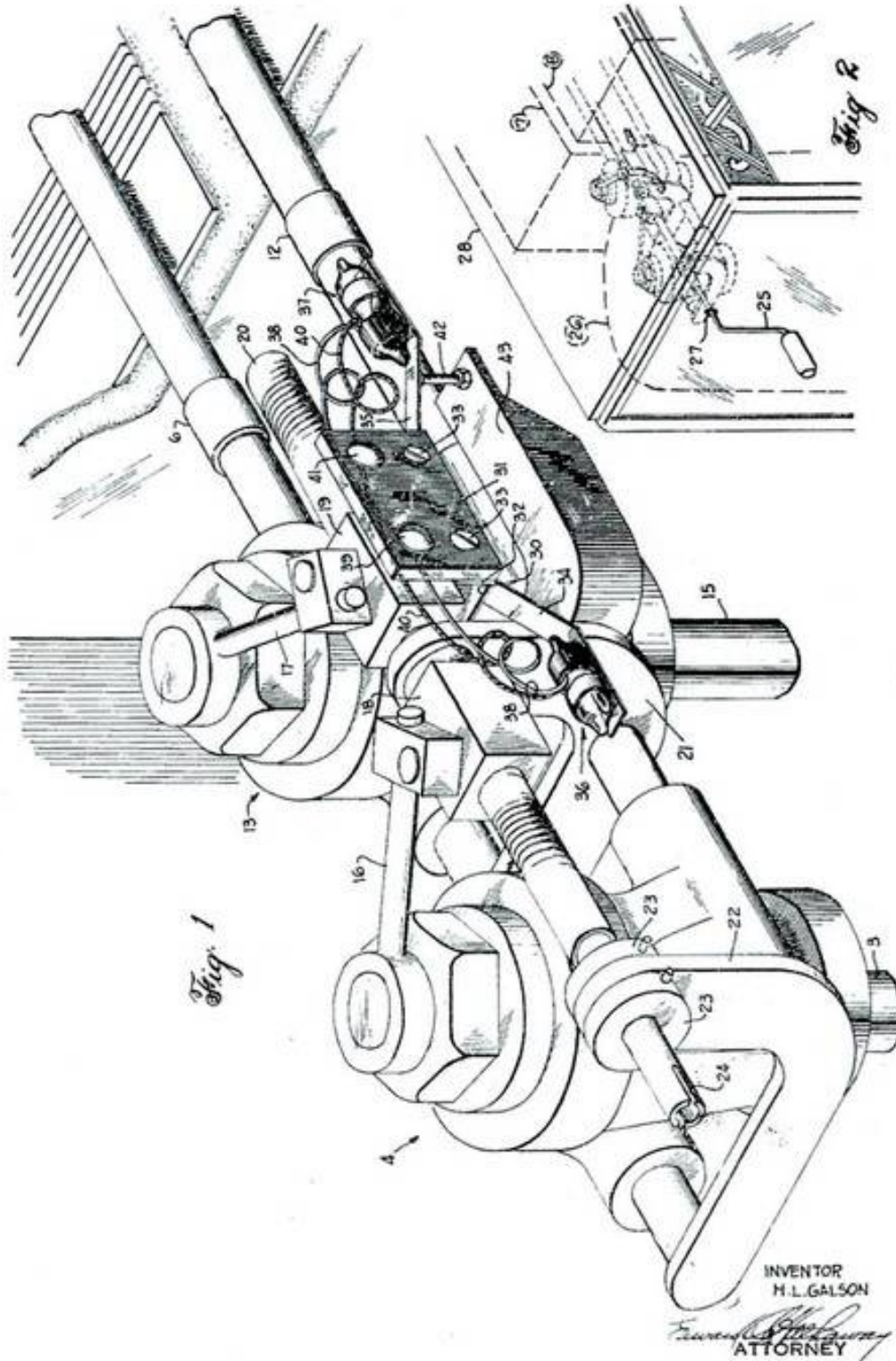

Sept. 13, 1938.

H. L. GALSON

2,130,327

AIR CONDITIONING APPARATUS

Filed Dec. 24, 1932

11 Sheets-Sheet 1

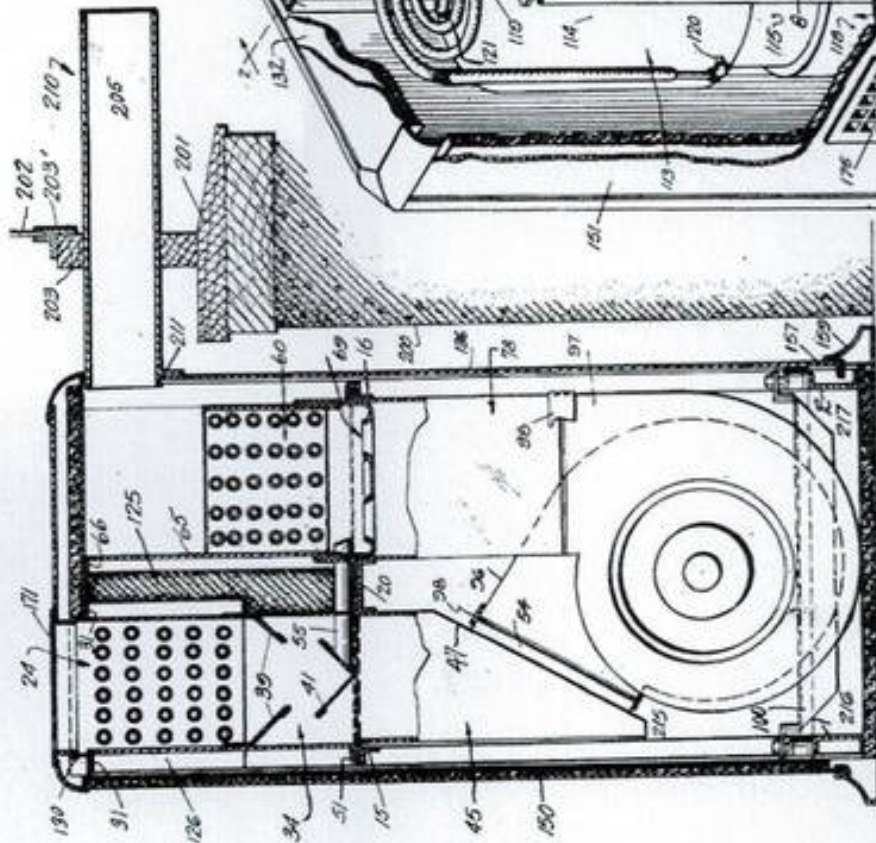
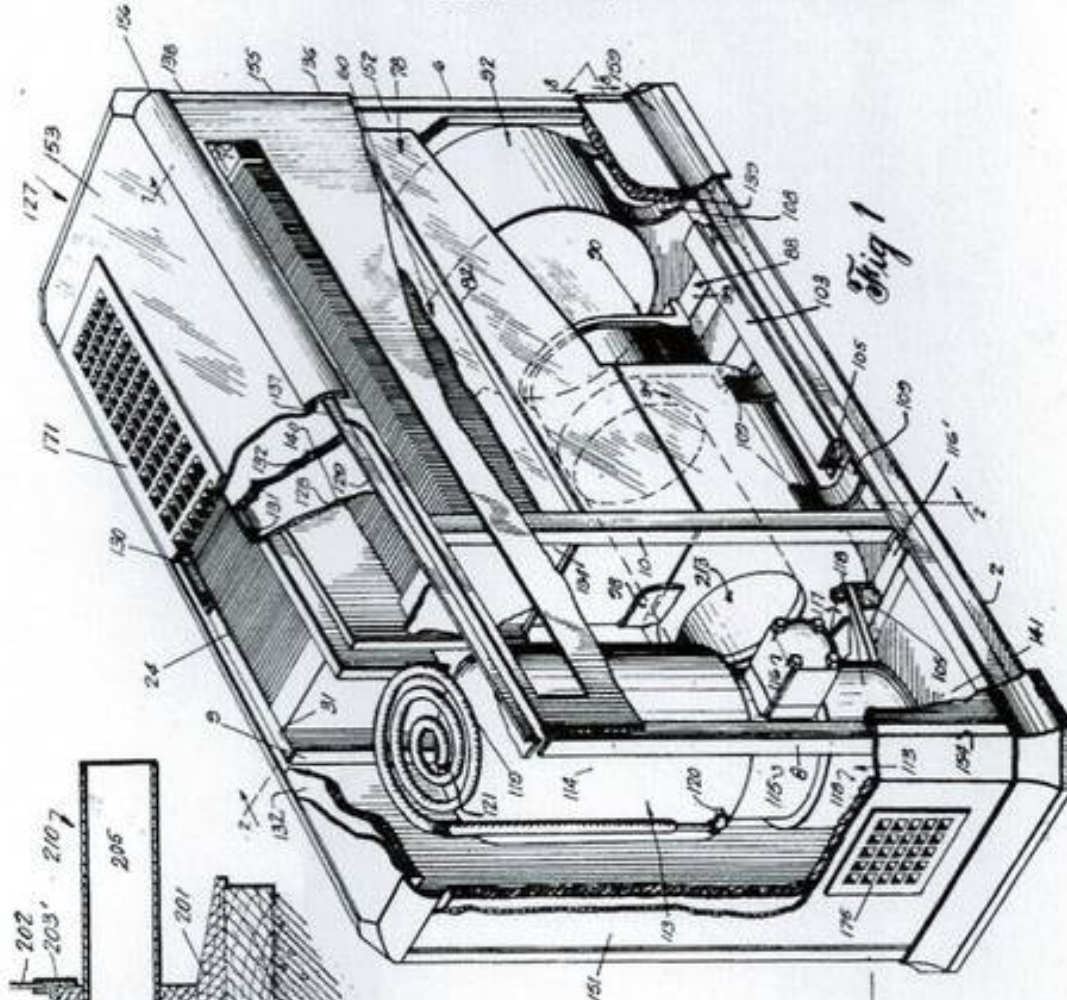

Fig. 2  
H. L. Galson  
By Edward J. Galson  
ATTORNEY

Sept. 13, 1938.

H. L. GALSON

2,130,327

AIR CONDITIONING APPARATUS

Filed Dec. 24, 1932

11 Sheets-Sheet 2

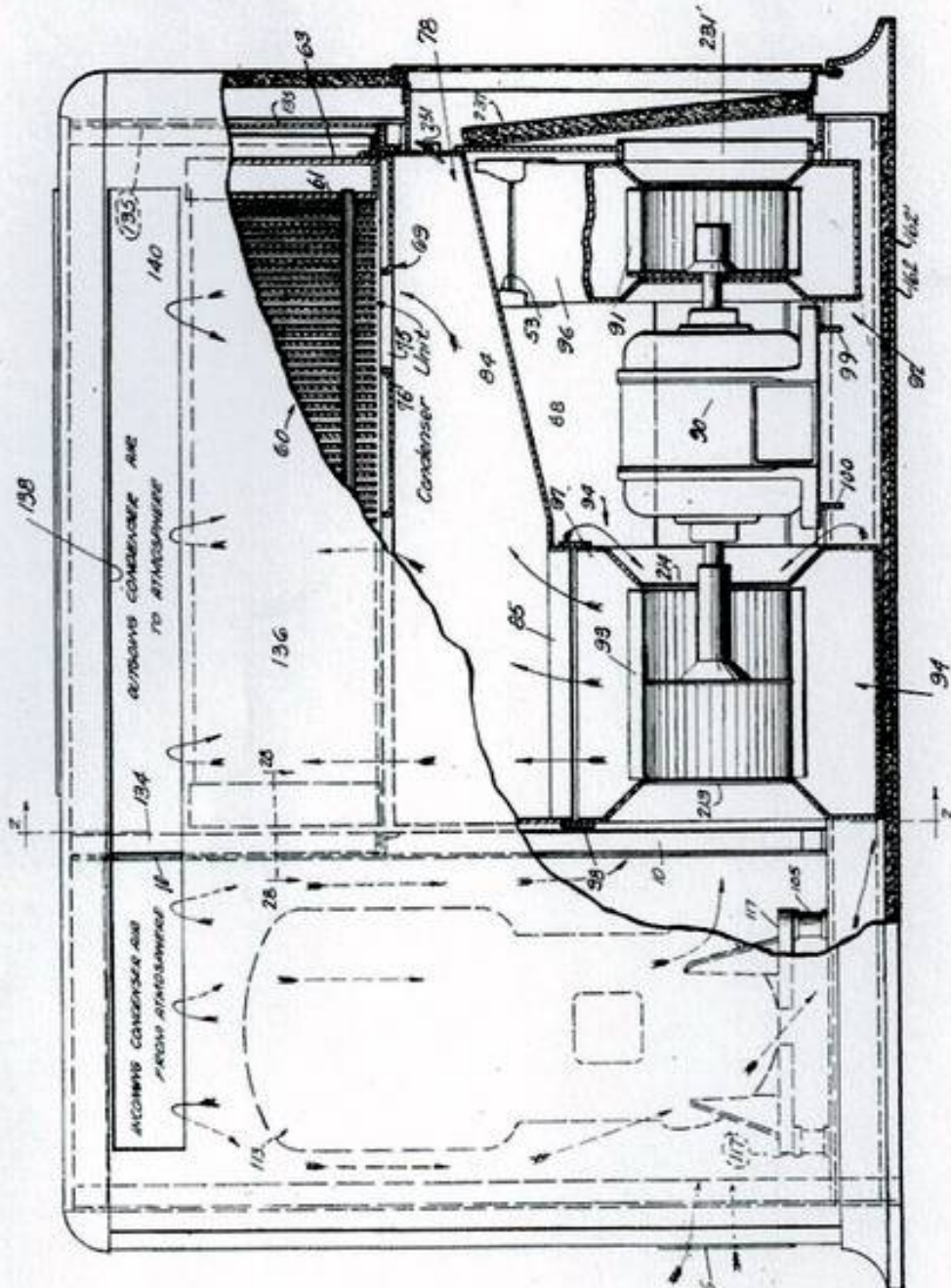

Fig. 3

INVENTOR  
*Henry L. Galson*  
BY  
*Charles H. [Signature]*  
ATTORNEY

Sept. 13, 1938.

H. L. GALSON

2,130,327

AIR CONDITIONING APPARATUS

Filed Dec. 24, 1932

11 Sheets-Sheet 3

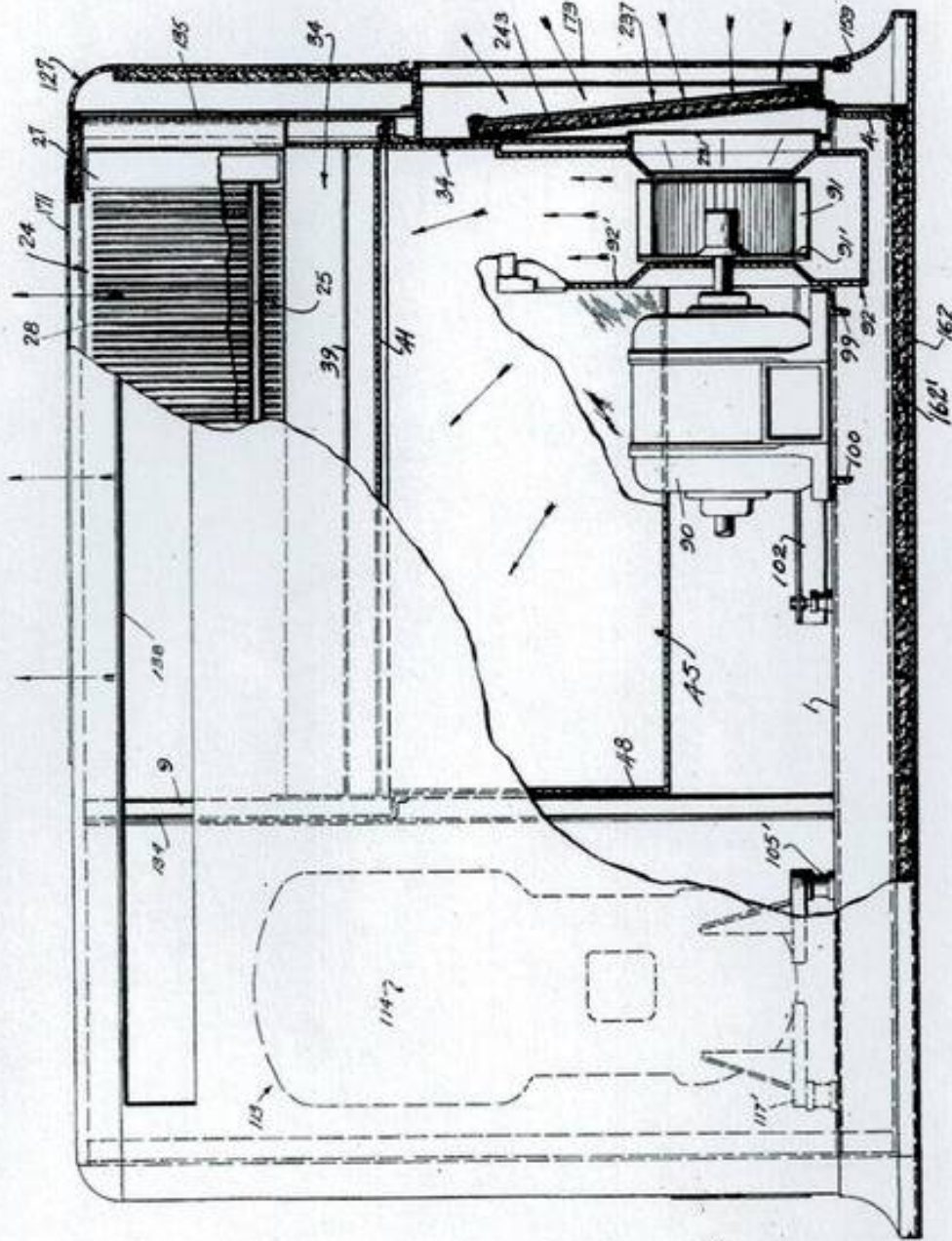

Fig. 4

INVENTOR  
*Henry L. Galson*  
BY  
*Edward J. [unclear]*  
ATTORNEY



Sept. 13, 1938.

H. L. GALSON

2,130,327

AIR CONDITIONING APPARATUS

Filed Dec. 24, 1932

11 Sheets-Sheet 9

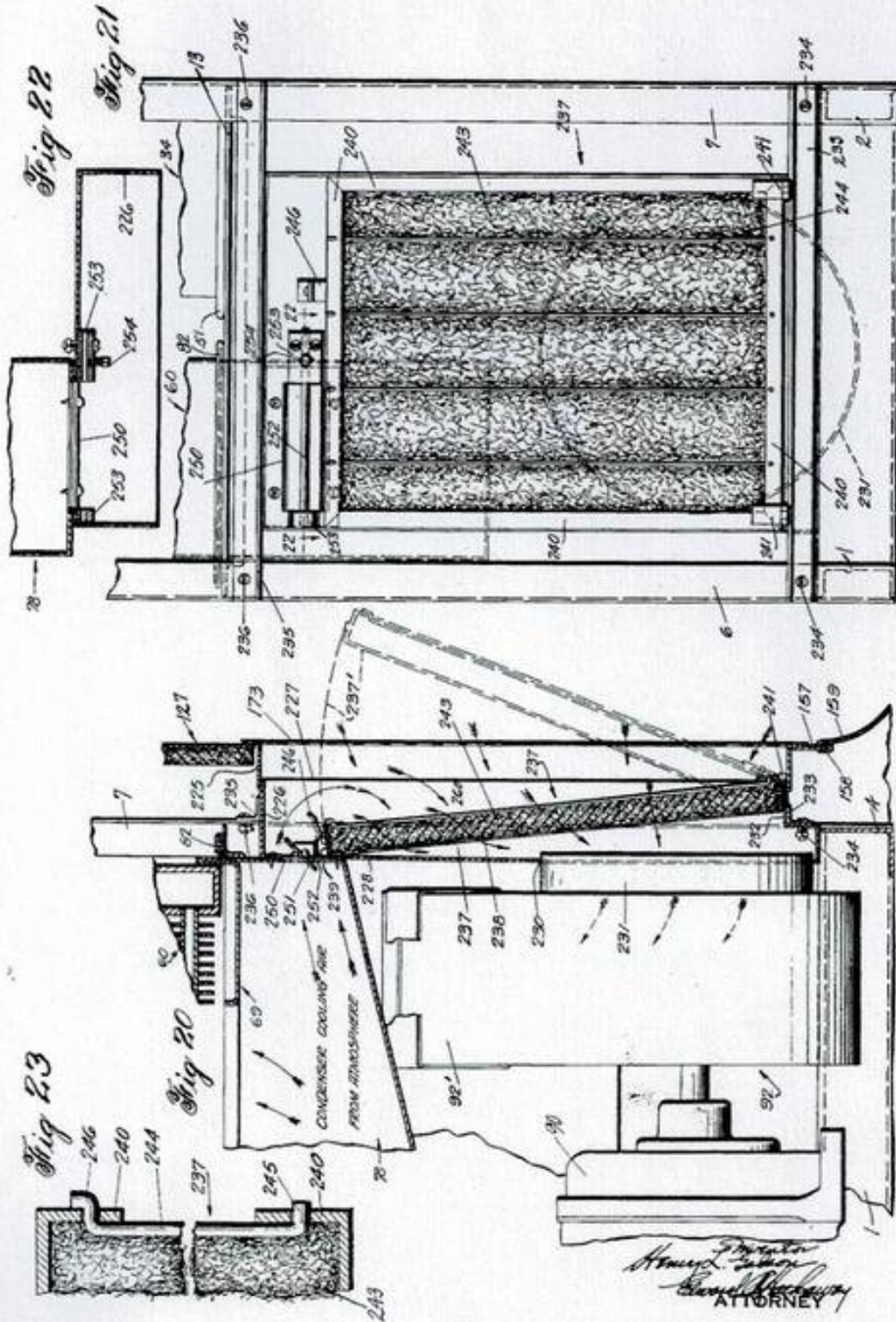

# UNITED STATES PATENT OFFICE

2,130,327

## AIR CONDITIONING APPARATUS

Henry L. Galson, Philadelphia, Pa., assignor to  
Baldwin-Southwark Corporation, a corporation  
of Delaware

Application December 24, 1932, Serial No. 648,772

72 Claims. (Cl. 62—129)

This invention relates generally to air conditioning apparatus and more particularly to an improved room cooler and ventilator for offices and homes.

5 In my present invention I have provided a self-contained portable room cooling unit employing a refrigerating system, the unit being so constructed and arranged that it may be conveniently placed in a room ready for immediate operation and will efficiently operate with utmost quiet and effectiveness so that occupants of the room will not be annoyed either from noises or drafts. I have also provided in one specific embodiment of the invention as shown herein an air cooled condenser contained within the unit, the unit and condenser being so arranged that the condenser heat may be adequately taken care of without affecting the room temperature. In a more specific aspect of the invention I have arranged the unit in an improved manner so that it will be highly compact and require minimum floor space whereby it may be placed adjacent a suitable opening in a wall of the room such as a window and at the same time insure that a large volume of outside air may be efficiently conducted into and out of the unit with full effectiveness in cooling the condenser. This improved arrangement necessitates blowers of only moderate size and the blowers and passages are so functionally related so as to obtain maximum volumetric capacity for the outside condenser cooling air even though the unit is compact and extends outwardly from the room wall for only a minimum distance. In addition to obtaining proper flow of the outside condenser cooling air in a compact unit, I am also able to insure proper and efficient flow of room air through the unit by providing an improved structural and functional relation between the various elements embodied in my unit. Irrespective of the type of condenser cooling system employed there are other improved features associated with my particular condenser cooling system so as to effectively adapt the unit for use in a home or office without unsightly appearance or mechanical complications.

In addition I have provided a unit that is not only compact so as to require minimum space but is also adapted to have an attractive exterior design and from a mechanical standpoint to have a relatively large refrigeration capacity to effect the desired degree of humidity control and air cooling. Inasmuch as the elimination or control of humidity is an essential factor in air conditioning, the room cooler is arranged in an improved

manner to adequately and efficiently take care of the eliminated humidity. In my invention the unit is so constructed and the parts so arranged that mechanically it may be economically manufactured in quantity production while maintaining high quality of workmanship and operation together with the utmost reliability when in the hands of the users.

It is one object of my invention to accomplish the foregoing and other results in a room cooler which is relatively inexpensive for a piece of apparatus of this character and yet will have an improved combination of elements so arranged and related that the unit has a high degree of compactness and simplicity of construction, design and arrangement of parts, and has improved means for effecting exterior atmospheric communication with the refrigerating equipment including the refrigerant condenser, although there are various features of the room cooler as disclosed herein that are applicable either to a water cooled condenser or to a room cooler employing refrigerating systems other than the compressor-condenser-expander circuit which is a specific form shown. It is also an object of my invention to have the elements of the unit highly adapted for manufacture and assembly in quantity production while at the same time permitting them to be readily accessible and easily dismantled or removed in case of the necessity of repair or replacement.

Another object is to provide improved means for collecting condensate resulting from the elimination of humidity which condenses on the evaporator and of ejecting or discharging this condensate to the atmosphere outside of the room, this being accomplished specifically by collecting the condensate in a pan or trough beneath the evaporator and conducting the condensate to an ejector pan beneath the condenser, whereby the condenser cooling air in blowing upwardly through ejector openings causes the water to be entrained in the stream of air and to be discharged to the exterior atmosphere although in being so discharged the moisture will be blown against the condenser to assist in cooling the same by re-evaporation.

A further object is to provide an improved room cooler adapted to effect positive ventilation by introducing into the room a portion of preferably filtered, cooled and dehumidified outside air, preferably under pressure and to either directly or indirectly exhaust a proportional amount of devitalized room air to the outside, and

## References

*Heat & Cold: Mastering the Great Indoors*, Barry Donaldson & Bernard Nagengast, ASHRAE, 1994

*Henry L Galson: Pioneer Designer of Self-Contained Air Conditioning Equipment*, Edgar L Galson & Allen E Galson, ASHRAE Journal, April, 1995

*The Comfort Makers*, Brian Roberts, ASHRAE, 2004

*The People's Air Conditioner: Henry Galson, 1900-1963*, Edgar L Galson, 100 Years of Refrigeration, A Supplement to ASHRAE Journal, November, 2004

*Henry L Galson*, ASHRAE Hall of Fame, 2005