

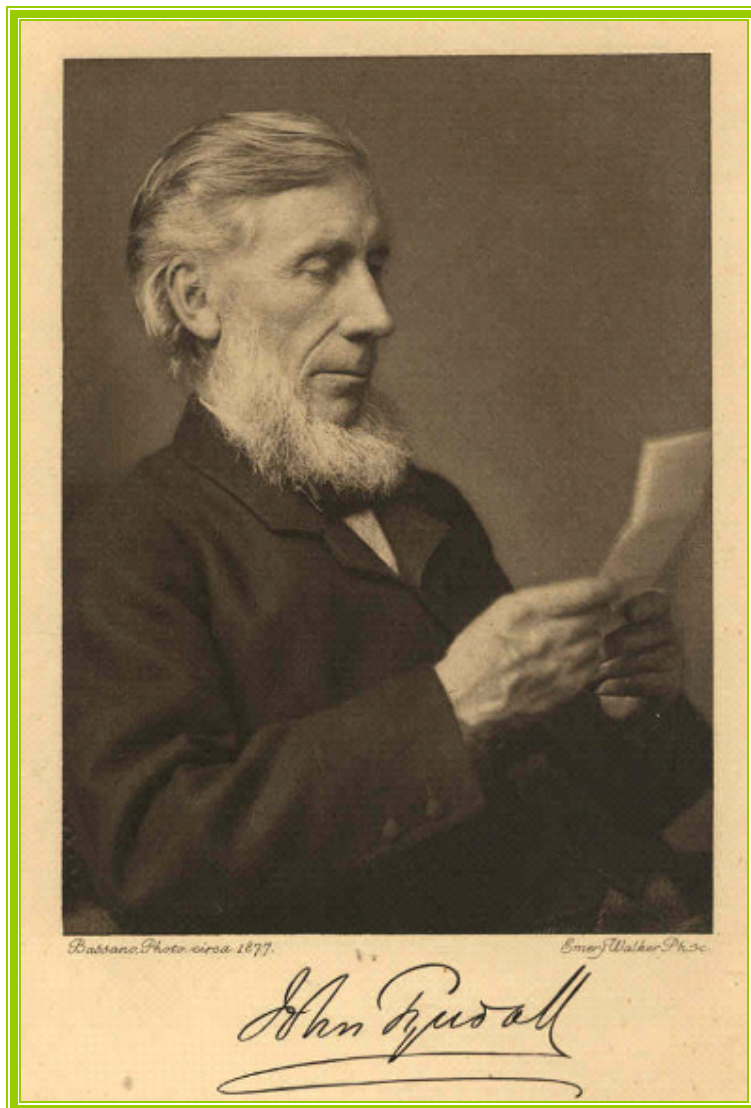

JOHN TYNDALL

1820-1893



*Pioneer in Acoustics and Heat
(CIBSE Heritage Group Collection)*

John Tyndall**1820-1893**

John Tyndall was born on Aug. 2, 1820, at Leighlin Bridge, near Carlow, Ireland, where his father was a constable. After a little formal schooling, he gained a practical education by working as a surveyor and engineer. He entered the University of Marburg, Germany, in 1848 and earned his doctorate 2 years later. His dissertation research interested Michael Faraday, who later brought him to the Royal Institution of London. In 1867 Tyndall succeeded Faraday as superintendent there. He was awarded the Rumford medal in 1864. He wrote the classic textbook "Heat: A Mode of Motion" and also "Sound" which dealt extensively with the theory of vibration.

(Mini-biography from CIBSE Heritage Group Records)

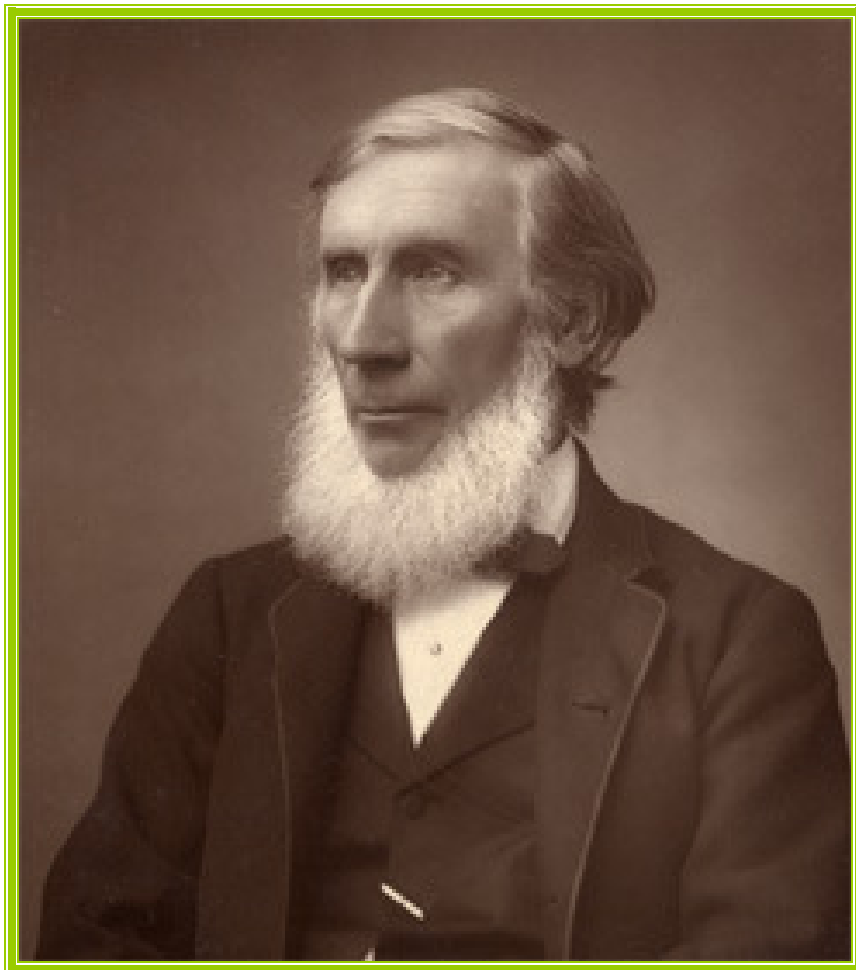

John Tyndall

Hales

S O U N D .

A COURSE OF

EIGHT LECTURES

DELIVERED AT

THE ROYAL INSTITUTION OF GREAT BRITAIN

BY

JOHN TYNDALL, LL.D. F.R.S.

PROFESSOR OF NATURAL PHILOSOPHY IN THE
ROYAL INSTITUTION AND IN THE ROYAL
SCHOOL OF MINES.

LONDON :

LONGMANS, GREEN, AND CO.

1867.

(Google Books)

Let me endeavour to illustrate the propagation of sound by another homely but useful illustration. I have here

FIG. 2.

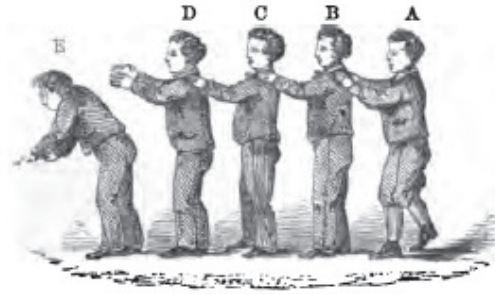

five young assistants, A, B, C, D, and E, fig. 2, placed in a row, one behind the other, each boy's hands resting against the back of the boy in front of him. E is now foremost, and A finishes the row behind. I suddenly push A ; A pushes

B, and regains his upright position ; B pushes C ; C pushes D ; D pushes E ; each boy, after the transmission of the push, becoming himself erect. E, having nobody in front, is thrown forward. Had he been standing on the edge of a precipice, he would have fallen over ; had he stood in contact with a window, he would have broken the glass ; had he been close to a drum-head, he would have shaken the drum. We could thus transmit a push through a row of a hundred boys, each particular boy, however, only swaying to and fro. Thus, also, we send sound through the air, and shake the drum of a distant ear, while each particular particle of the air concerned in the transmission of the pulse makes only a small oscillation.

(Extract from "Sound")

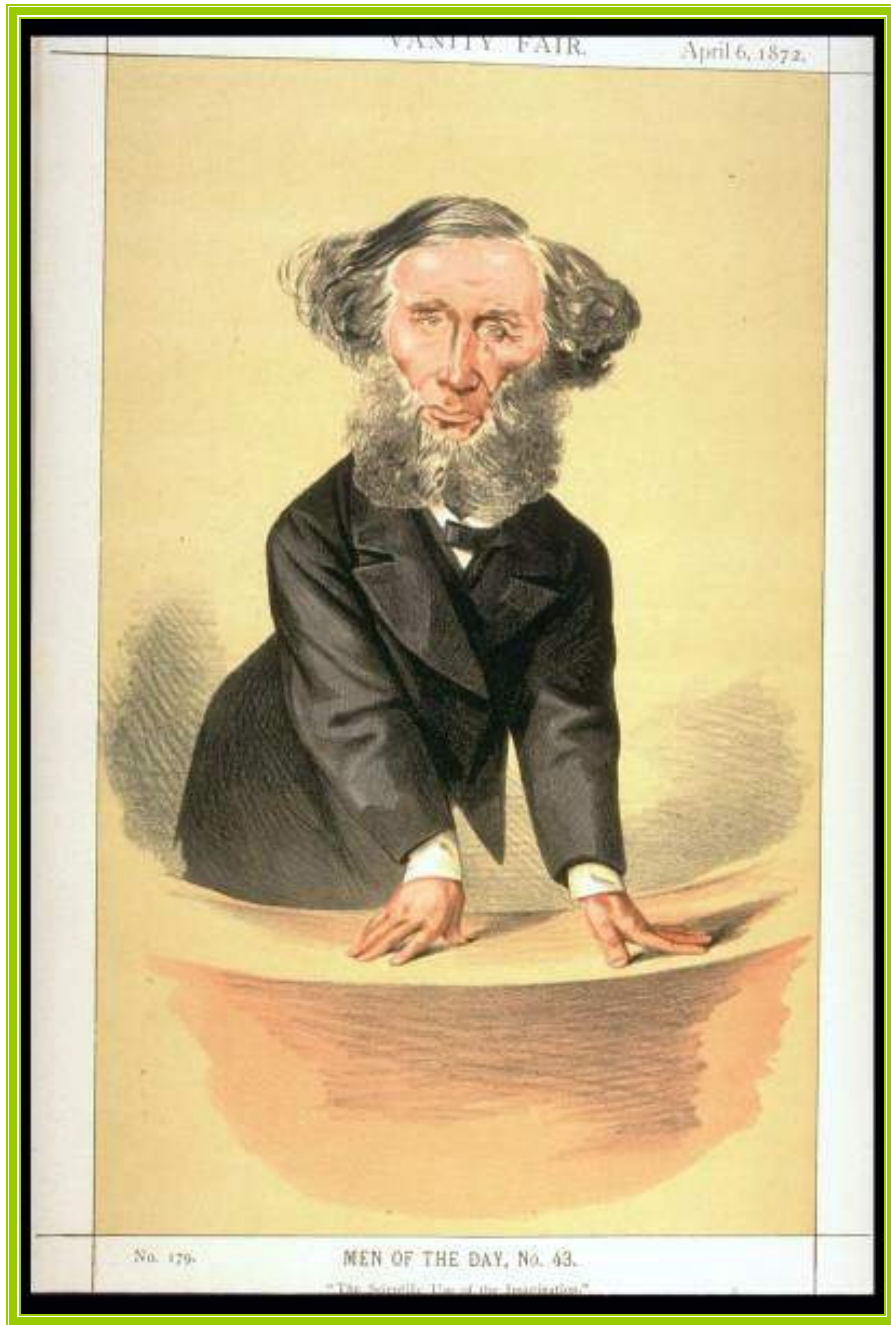

Cartoon of John Tyndall (Vanity Fair, 6 April 1872)

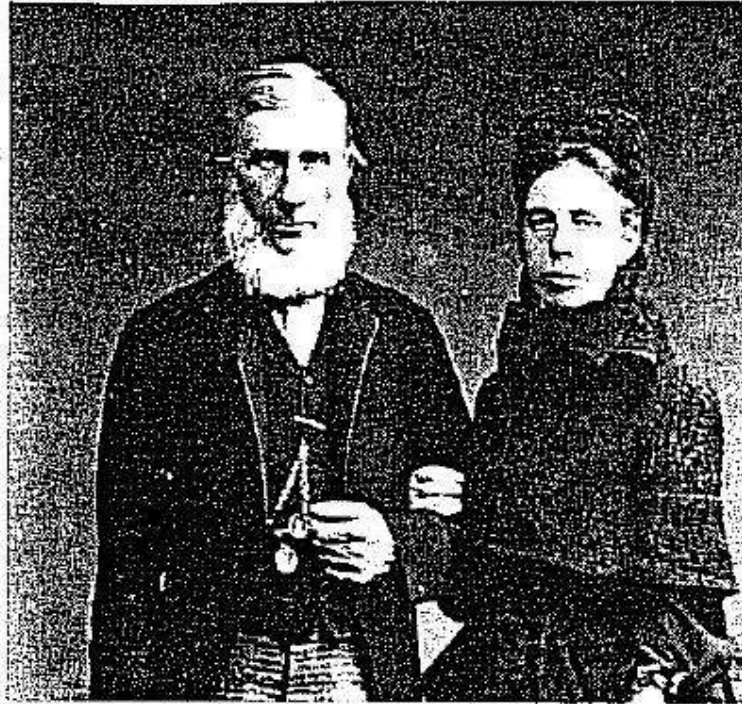

*Fig. 1.2. John and Louisa Tyndall in 1884.
Photograph by Elliott and Fry. (Courtesy Royal Institution)*

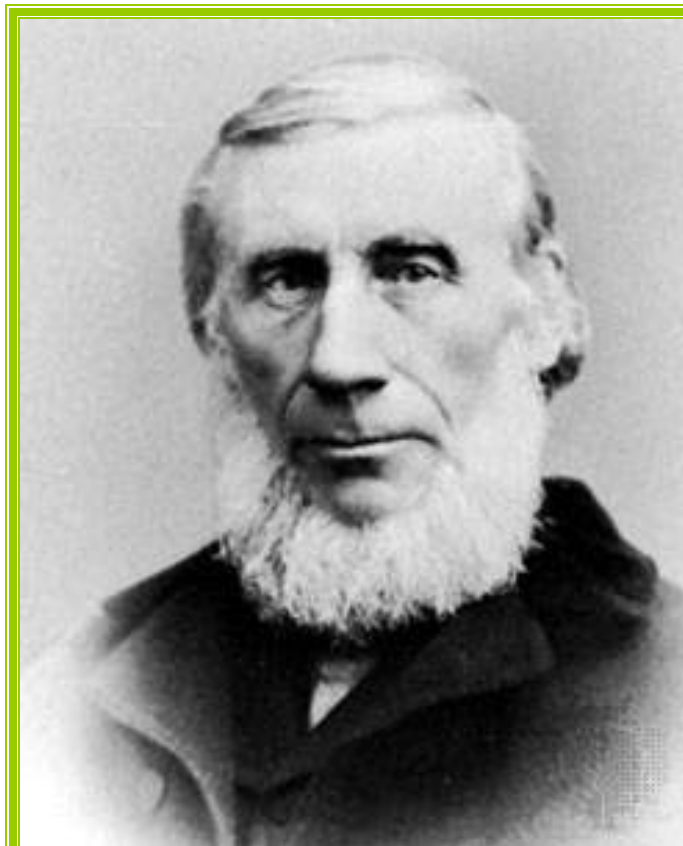

HEAT

A MODE OF MOTION

BY

JOHN TYNDALL, D.C.L., LL.D., F.R.S.

HONORARY PROFESSOR OF NATURAL PHILOSOPHY IN
THE ROYAL INSTITUTION OF GREAT BRITAIN

THIRTEENTH IMPRESSION

(17th Thousand)

WITH PORTRAIT AND FOLDING PLATE

LONGMANS, GREEN, AND CO.

39 PATERNOSTER ROW, LONDON
NEW YORK, BOMBAY AND CALCUTTA

1908

All rights reserved

(CIBSE Heritage Group Collection)



Dr ANDREW URE
1778-1857

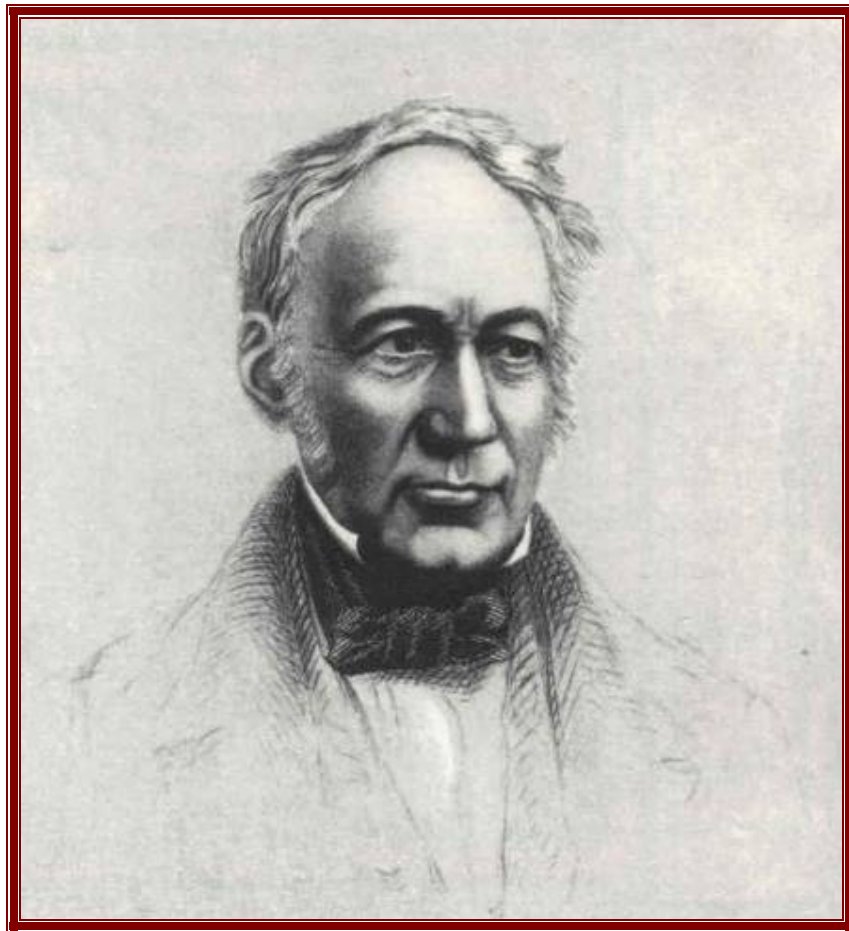

Coined the word "thermostat"

[125] Andrew URE

1778-1857

Born in Scotland. Doctor of Medicine (Glasgow, 1801). Professor of Chemistry and Natural Philosophy. Appointed analytical chemist to the Board of Customs in London (1830). Granted a patent for *An Apparatus for Regulating Temperature in Vaporisation, Distillation and Other Processes* (BP 6014: 1830). He coined the word *thermostat*. He designed an air-heating stove with thermostatic control (BP 6016: 1830). Ure is also remembered for his *Dictionary of Arts, Manufactures and Mines* (1839).

(Mini-biography from "The Comfort Makers," Brian Roberts, ASHRAE, 2000)

Modern Thermostatic Control—Andrew Ure

Prior to Arnott's work on his "thermometer stove," Andrew Ure (1778-1857) (Figure 10-7) had been working on defining the latent heat of different vapors²⁵ as well as the design of a thermostat in 1830, which he patented in 1831.

He gained his doctor of medicine degree at Glasgow in 1801 and became a professor of chemistry and natural philosophy at the Andersonian Institution in 1802. He moved to London in 1830 and was appointed analytical chemist to the Board of Customs in 1834. He was the author of a number of scientific and philosophical works; his *Dictionary of Arts, Manufactures and Mines*, published in 1839, was printed in several editions both in England and in the United States. Dr. Ure's claim to fame is based on a patent granted to him in 1830 (No. 6014) entitled "An Apparatus for Regulating Temperature in Vaporization, Distillation and Other Processes." In the specification, several forms of automatic temperature control apparatus are described and shown.²⁶

Ure's thermostat, for the control of steam-heating coils, was the first of its kind. It was a bimetallic device of brass and iron whose design could be modified for controlling air or water temperatures.

THERMOSTAT, is the name of an apparatus for regulating temperature, in vaporization, distillation, heating baths or hothouses, and ventilating apartments &c.; for which I obtained a patent in the year 1831. It operates upon the physical principle, that when two thin metallic bars of different expandabilities are riveted or soldered facewise together, any change of temperature in them will cause a sensible movement of flexure in the compound bar, to one side or other; which movement may be made to operate, by the intervention of levers, &c., in any desired degree, upon valves, stopcocks, stove-registers, air-ventilators, &c.; so as to regulate the temperature of the media in which the said compound bars are placed. Two long rulers, one of steel, and one of hard hammered brass, riveted together, answer very well; the object being not simply to indicate, but to control or modify temperature.²⁷

The honor of naming the heat governor the "thermostat" and of indicating wider industrial applications for it than had previously been suggested belongs to Ure.

Altogether Ure was granted five patents in one of which (No. 6016/1830) he described an air-heating stove with a thermostatic control. There is no record of Ure's thermostat ever getting into industrial use, and it is doubtful whether it would have had any success in practice because the riveting together of the two metal strips is unsatisfactory and it was not until a method of firmly uniting them by heat treatment was found that the bimetallic strip became a dependable component for a heat governor (Figures 10-9 and 10-10).²⁸

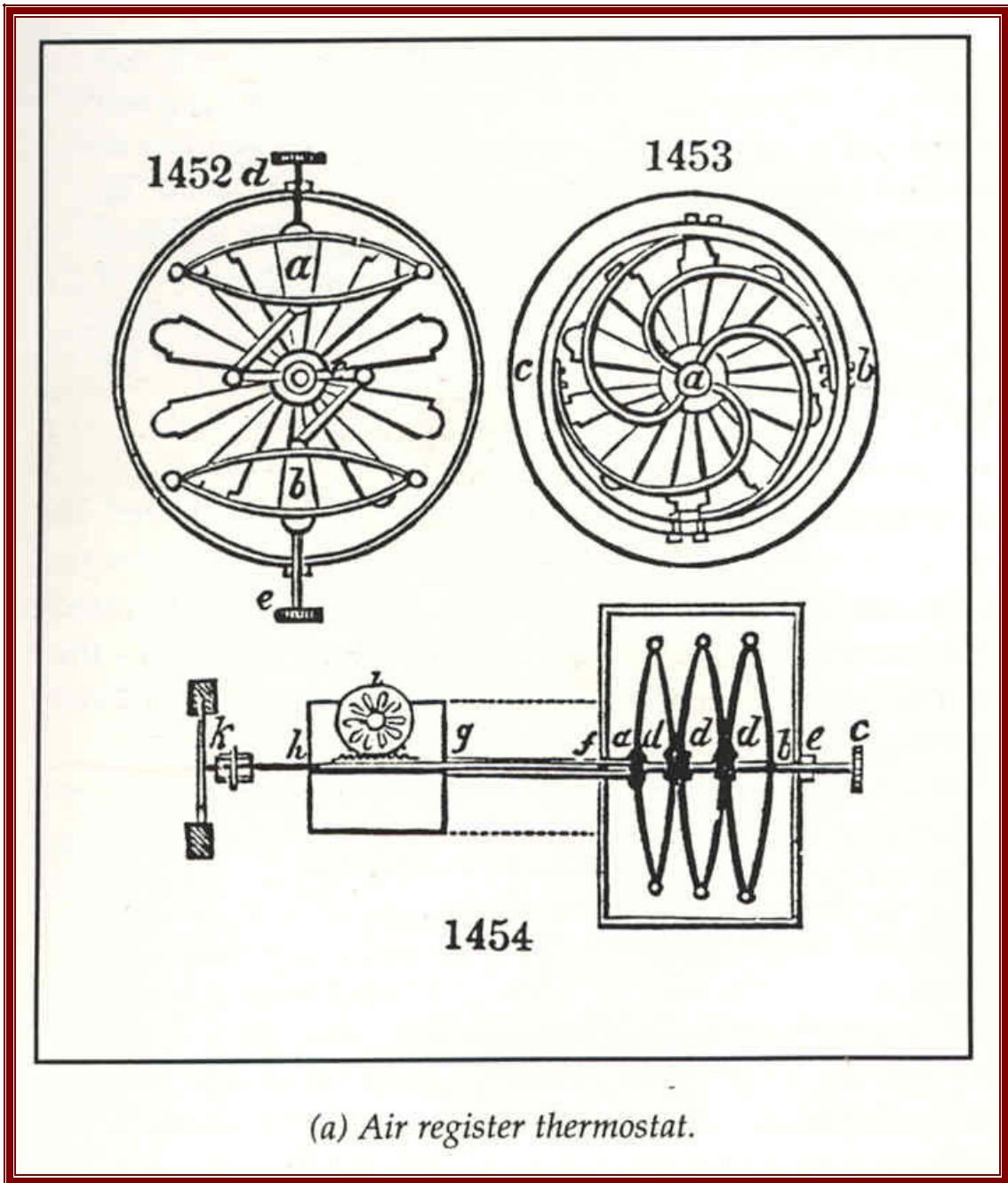

(a) Air register thermostat.

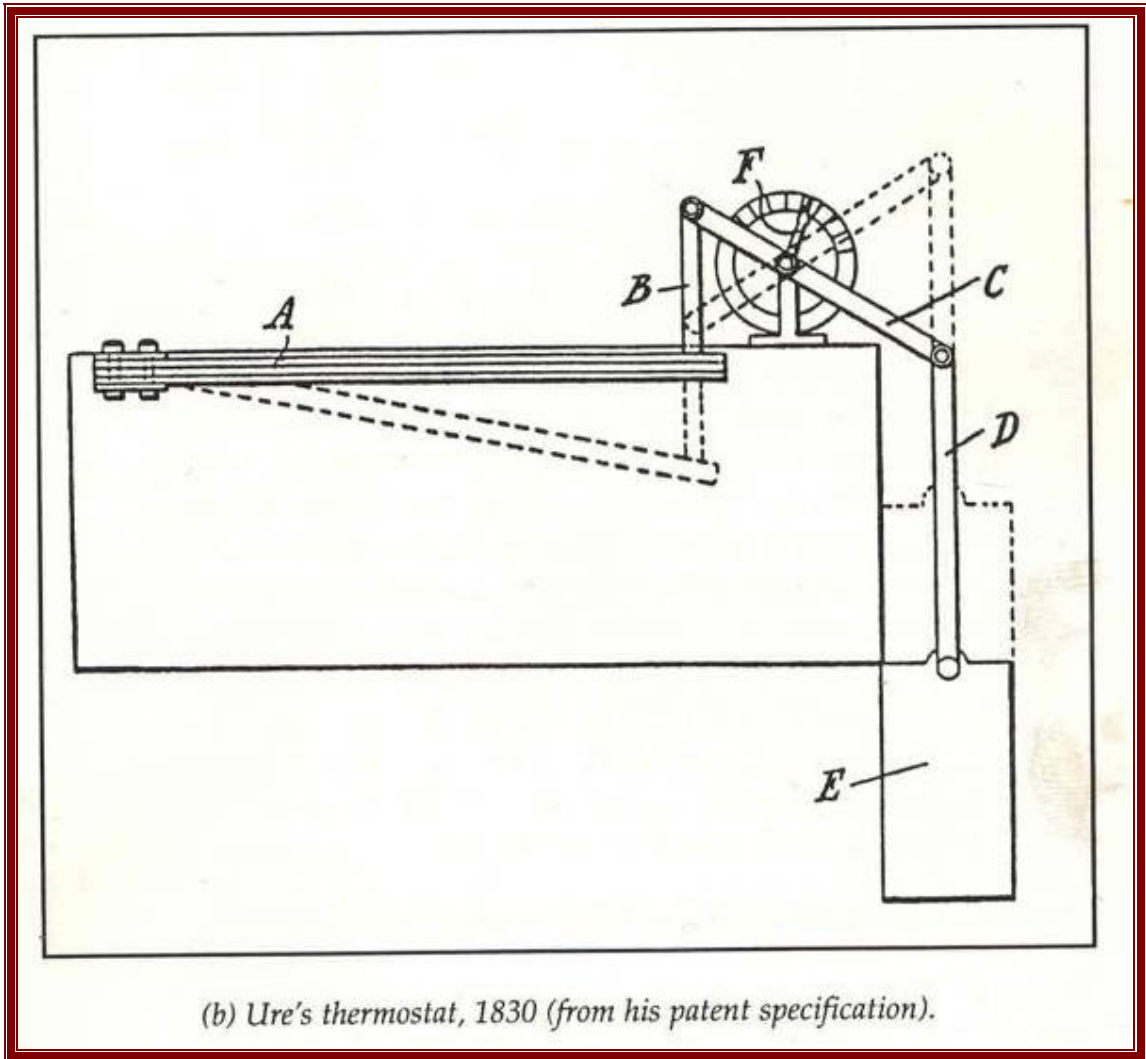

(b) Ure's thermostat, 1830 (from his patent specification).

(Text and pictures from "Heat & Cold: Mastering the Great Indoors,"
Barry Donaldson & Bernard Nagengast, ASHRAE, 1994)

A
D
CTIONARY
OF
ARTS, MANUFACTURES, AND MINES:

CONTAINING

A CLEAR EXPOSITION OF THEIR PRINCIPLES AND PRACTICE.

BY ANDREW URE, M.D.

F.R.S. M.G.S. M.A.S. LOND.; M. ACAD. N.S. PHILAD.; S. PH. SOC. N. GERM. HANOV.; MULL. ETC. ETC.

Illustrated with nearly Sixteen Hundred Engravings on Wood.

FOURTH EDITION,
CORRECTED AND GREATLY ENLARGED.

IN TWO VOLUMES.—VOL. II.

BOSTON:
LITTLE, BROWN AND CO.
1853.

Ure's "Dictionary" of 1853 (Google Books)



JOHN DE LA VERGNE
Active 1880's

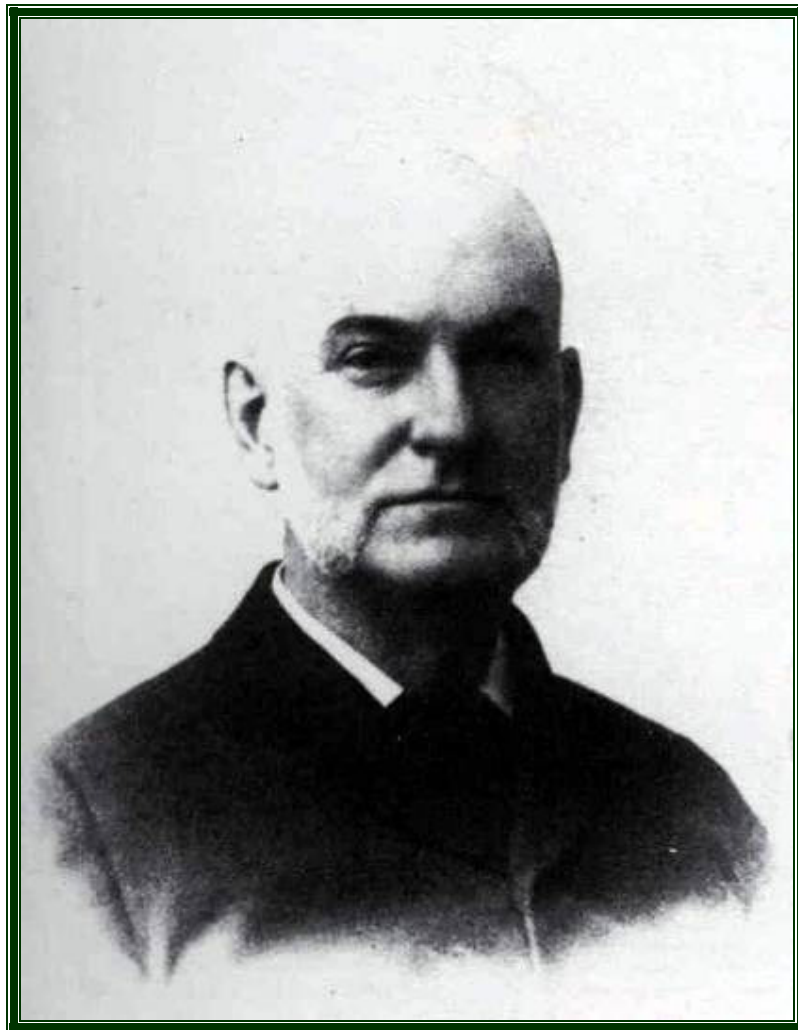

Pioneer of large ammonia refrigerating machines, often steam-driven

Figure 9-30 Refrigerating engineer and manufacturer John De La Vergne was known for his sense of humor, which can be seen in engineer Louis Block's reminiscence of a dinner given in celebration of the sale of the 100th refrigerating plant by the De La Vergne Refrigerating Machine Co. in 1887: "The host of the evening was attired in the superb costume of a Polar Bear, en train, with flashing icicles and boxing gloves. He looked entirely frozen, as is his wont and main characteristic, and whenever he found occasion to use his handkerchief, a sweet yet subdued odor of Rimmel's double extract of anhydrous ammonia filled the lambent air of the banquet hall. He moved among his guests with that air of perfect repose, which is only found among the dwellers on latitudes of a very low thermometer" (L. Block, 1916, "Recollections of a quarter-century experience," *Ice and Refrigeration*, November, p. 146) (from: *Ice and Refrigeration*, June 1896, p. 387).

(From "Heat & Cold: Mastering the Great Indoors,"
Barry Donaldson & Bernard Nagengast, ASHRAE, 1994)

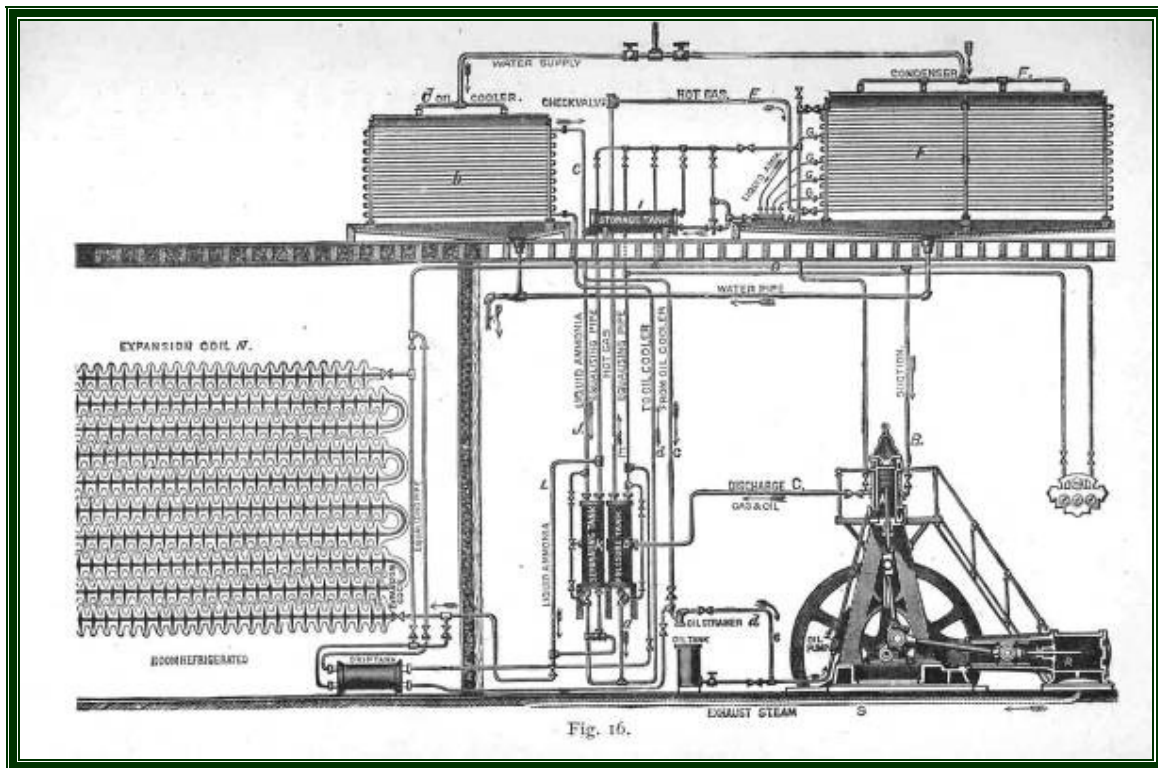

(From Wallis-Taylor)

REFRIGERATING
AND
ICE - MAKING MACHINERY



A. J. WALLIS - TAYLER

(CIBSE Heritage Group Collection)

REFRIGERATING AND ICE-MAKING MACHINERY

*A DESCRIPTIVE TREATISE FOR THE USE OF PERSONS
EMPLOYING REFRIGERATING AND ICE-MAKING
INSTALLATIONS, AND OTHERS*

BY
A. J. WALLIS-TAYLER, C.E.

ASSOC. MEMB. INST. C. E.

AUTHOR OF "REFRIGERATION AND COLD STORAGE," "SUGAR MACHINERY," "TRA MACHINERY,"
"BEARINGS AND LUBRICATION," "AERIAL OR WIRE ROPE TRAMWAYS,"
"THE SANITARY ARRANGEMENT OF DWELLING-HOUSES,"
ETC., ETC.

THIRD EDITION, WITH ADDITIONS

Illustrated with about One Hundred Diagrams



LONDON
CROSBY LOCKWOOD AND SON
7, STATIONERS' HALL COURT, LUDGATE HILL
1902

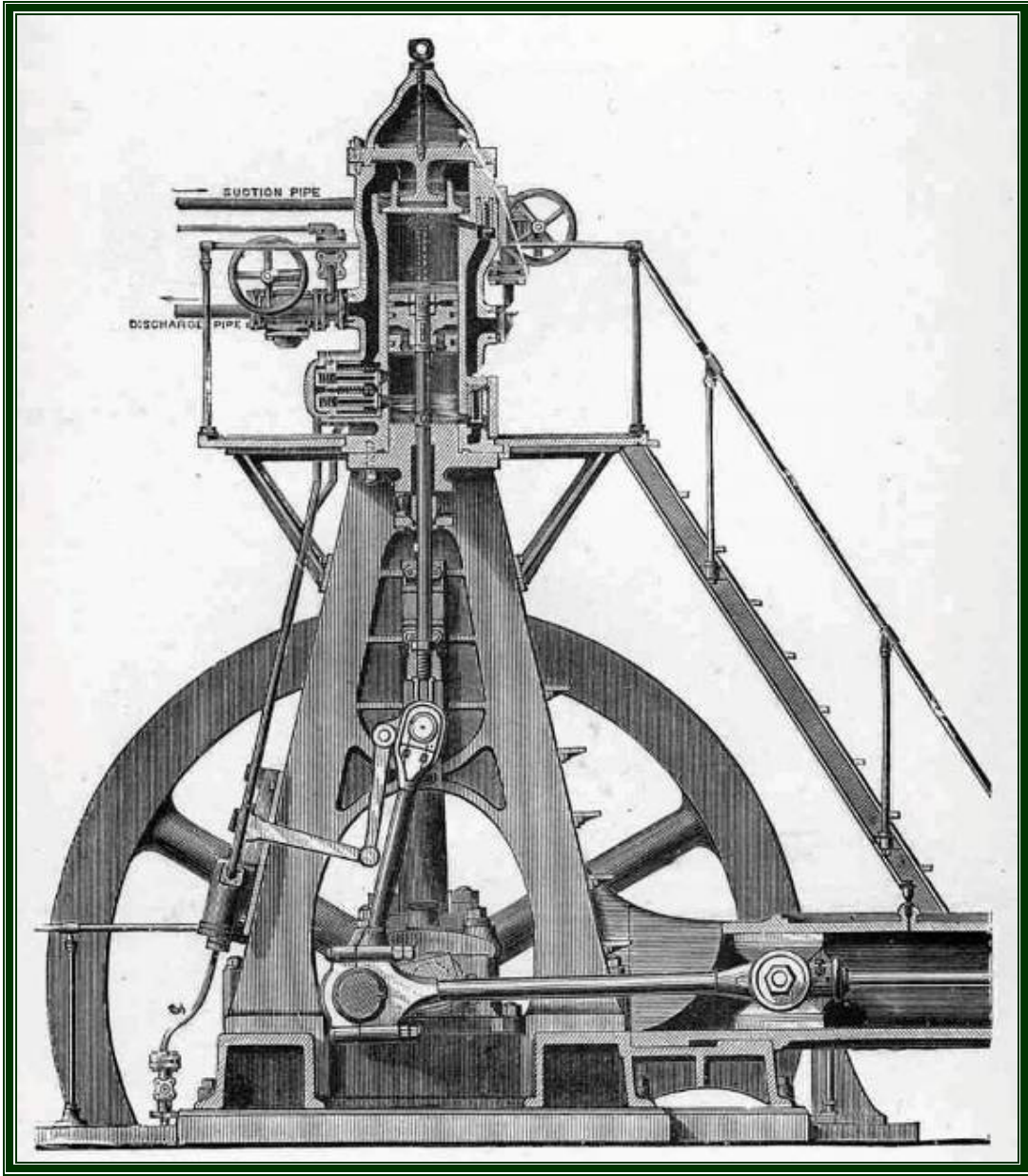

*(From Wallis-Taylor)
De La Vergne machines were manufactured in Britain by L Sterne Company*

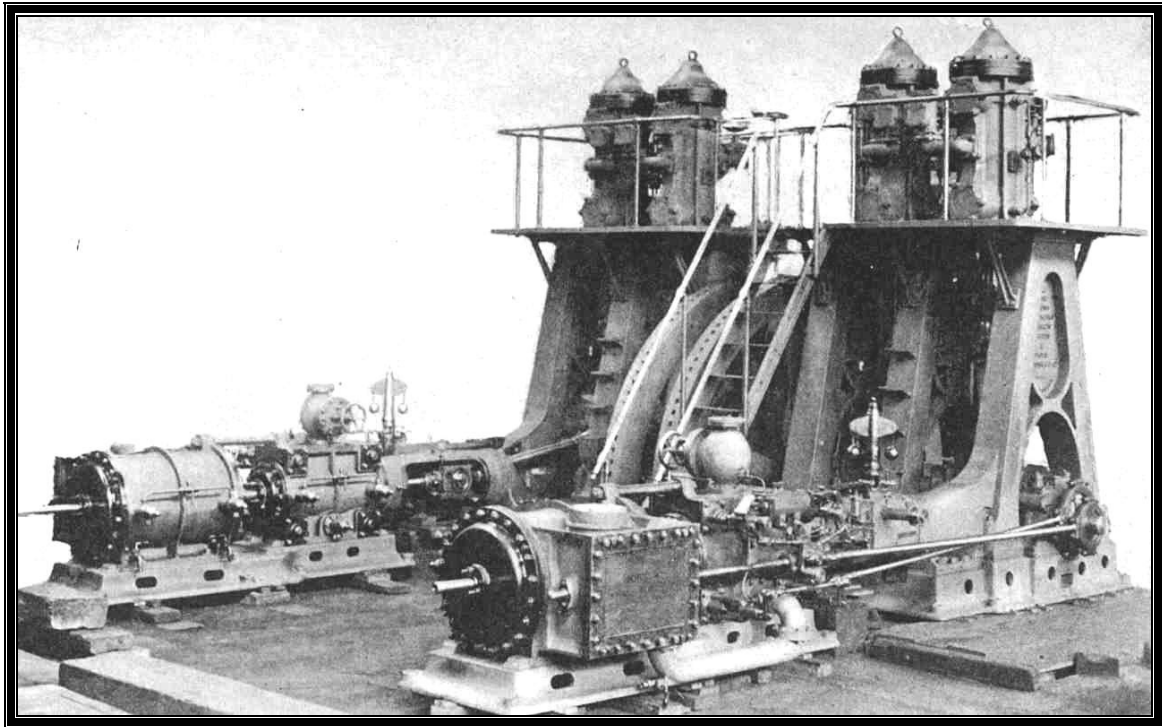

*Two compound horizontal engines each driving two vertical double-acting compressors.
Refrigeration plant by L Sterne Company*

*(From "Refrigeration," J Wemyss Anderson, 1908,
CIBSE Heritage Group Collection)*

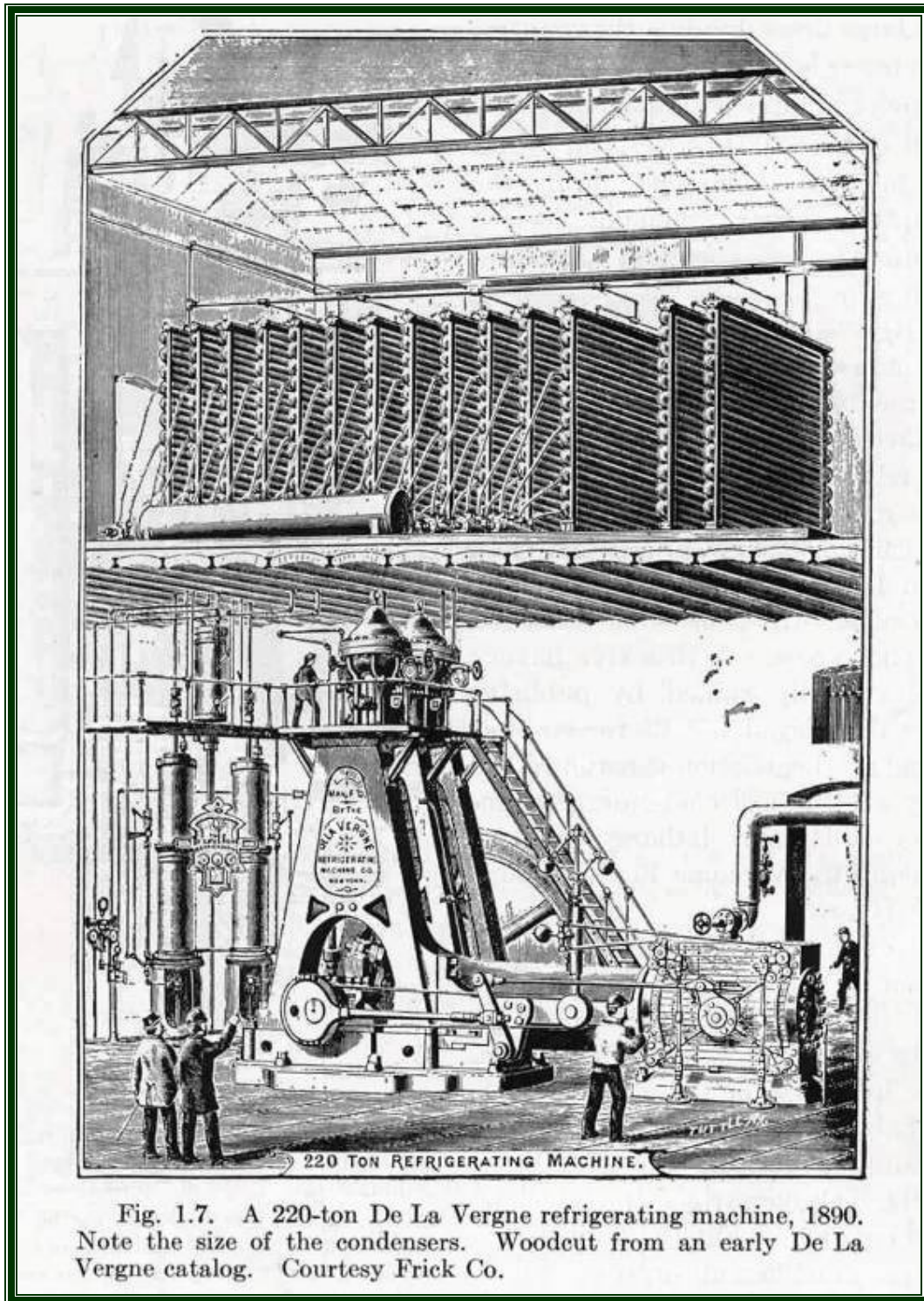

Fig. 1.7. A 220-ton De La Vergne refrigerating machine, 1890. Note the size of the condensers. Woodcut from an early De La Vergne catalog. Courtesy Frick Co.

(From "Refrigeration and Air Conditioning," Richard C Jordan & Gayle B Priester, 1956)
Note the "Atmospheric" Condenser Coils, ie. No fan-assisted airflow

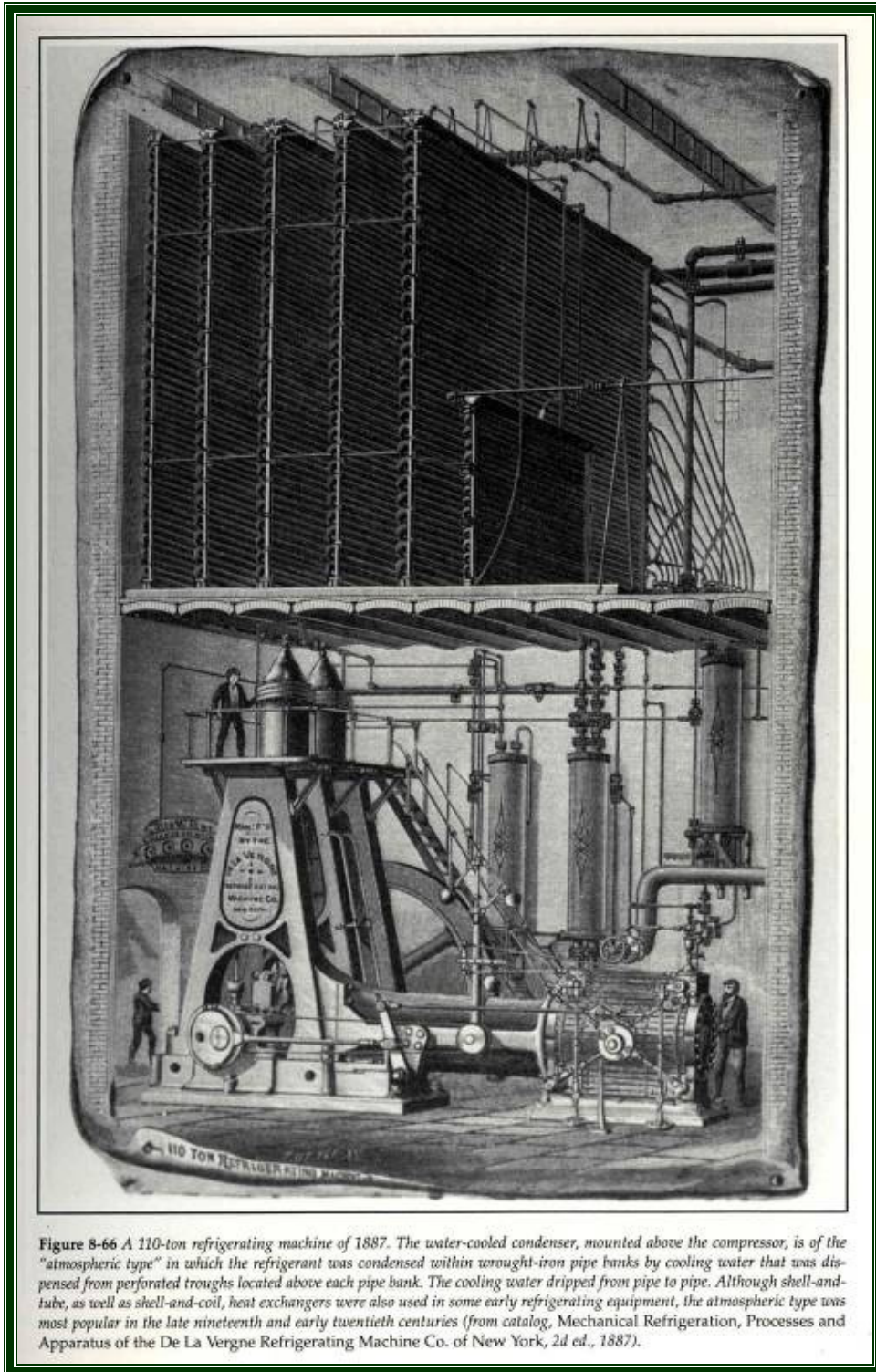

Figure 8-66 A 110-ton refrigerating machine of 1887. The water-cooled condenser, mounted above the compressor, is of the "atmospheric type" in which the refrigerant was condensed within wrought-iron pipe banks by cooling water that was dispensed from perforated troughs located above each pipe bank. The cooling water dripped from pipe to pipe. Although shell-and-tube, as well as shell-and-coil, heat exchangers were also used in some early refrigerating equipment, the atmospheric type was most popular in the late nineteenth and early twentieth centuries (from catalog, Mechanical Refrigeration, Processes and Apparatus of the De La Vergne Refrigerating Machine Co. of New York, 2d ed., 1887).

*(From "Heat & Cold: Mastering the Great Indoors,"
 Barry Donaldson & Bernard Nagengast, ASHRAE, 1994)
 This machine is half the refrigerating capacity of that in the preceding
 illustration, hence the smaller surface of condenser coils*

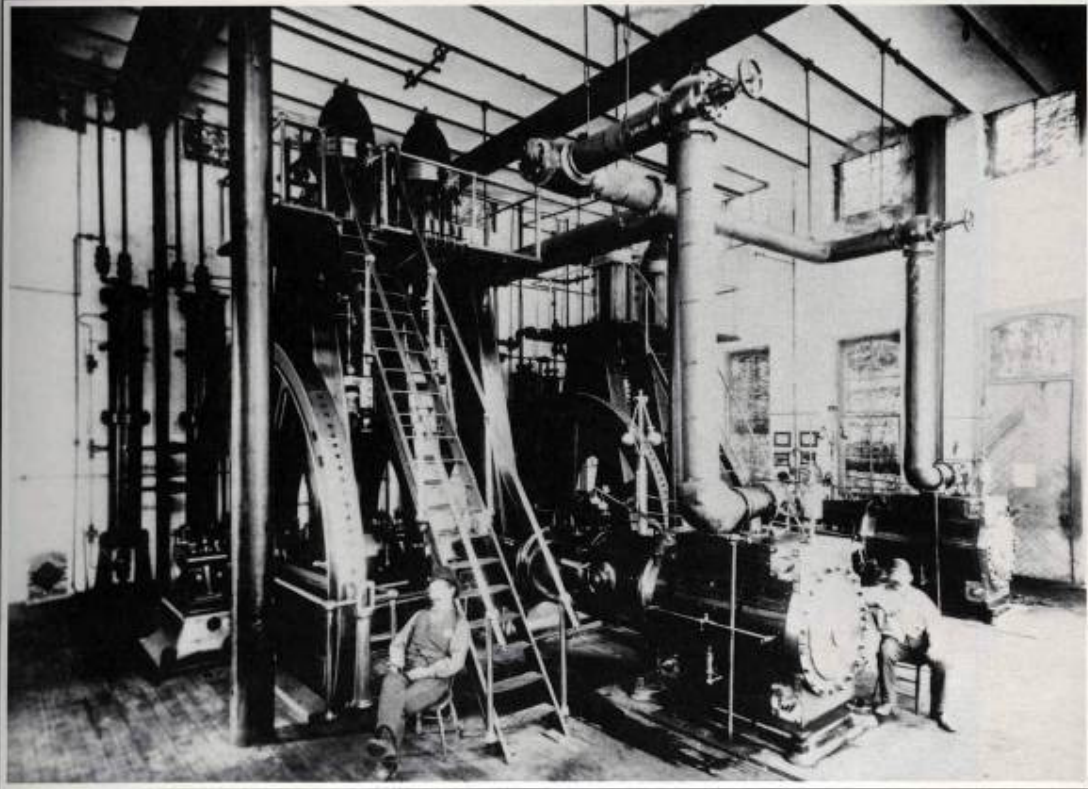

Figure 8-59 Typical open-crankcase, steam-engine-driven ammonia compressor from late 1800s. The machines weighed tens of thousands of pounds, operated at slow speeds, and seemed to last forever if properly cared for. The machine in the photo was made by the De La Vergne Refrigerating Machine Co. (from National Gallery of Canada; photo provided by Smithsonian Institution, Division of Engineering and Industry, Washington, D.C., De La Vergne file).

(From "Heat & Cold")



GARDNER T VOORHEES
1869-1937



Air Conditioning & Refrigeration Pioneer

GARDNER T VOORHEES**1869 — 1937**

Gardner T Voorhees was an early pioneer in refrigeration, refrigeration standards and air conditioning. He made many pioneering contributions. Among the most notable was his design of one of the earliest refrigerated district systems. This consisted of a central refrigeration plant serving multiple buildings using brine distributed through insulated underground pipes and was installed at the Quincy Market Cold Storage Company. Voorhees also designed one of the world's earliest comfort cooling systems, which was installed in his office at Quincy Market. He also designed and installed an air-conditioning system for the Walter Lowney Candy Company in Boston. All of these systems date from the 1890's. Voorhees authored five books on absorption and mechanical refrigerating machines, and held a patent on a dual suction-pressure compressor. Gardner T. Voorhees was inducted into the ASHRAE Hall of Fame in 2005.

(Edited extract from ASHRAE "Hall of Fame" Citation)

Sometime prior to 1903, refrigeration engineer Gardner T. Voorhees had cooled his Boston offices for many years. Voorhees was initially in charge of the refrigeration plans for the Louisiana Purchase Exposition (the St. Louis World's Fair) of 1904-1905. Voorhees proposed an ambitious program to comfort cool the Fair's refrigeration bureau office to demonstrate the usefulness of comfort cooling and to entice commercial participants to hook up to the Fair's central refrigeration plant for air-cooling purposes.⁵⁷ It seems that the Fair administration broke their contract, and Voorhees later said:

In my opinion, many practical uses of refrigeration were put back twenty-five years or more by the action of the St. Louis World's Fair Officials in breaking their contracts. . . .

It may be stated that with the enormous capacity of the proposed plant at St. Louis and the strong desire of many concessionaires to have their exhibits, theaters, restaurants, etc. thus cooled, a most wonderful opportunity was lost to have shown what I believe is one of the greatest coming uses of refrigeration, that is, cooling of what might be called peopled rooms for the comfort of (those) therein.⁵⁸

At this large public gathering place, the State of Missouri building contained a rotunda and 1,000-seat auditorium that were cooled during the summer. Approximately 35,000 cfm of partially recirculated air, cooled by direct expansion, was delivered through mid-height wall registers⁵⁹ (Figure 11-37). No doubt this installation impressed Fair visitors, many of whom experienced comfort cooling for the first time. But it really caused a stir among refrigeration engineers, causing *Ice and Refrigeration* to run an extended article on the installation. The editors concluded:

The practical application of mechanical refrigeration to air cooling for the purposes of personal comfort, no doubt has a field, . . . and the day is at hand, or soon will be, when the modern office building, factory, church, theater and even residence will be incomplete without a mechanical air cooling plant.⁶⁰



MISSOURI BUILDING.
An appropriation of \$1,000,000 was made by Missouri for the Fair.

Figure 11-37 The Missouri State Building at the Louisiana Purchase Exposition (the St. Louis World's Fair) of 1904. The building was equipped with central air cooling and it was the first time that comfort cooling was experienced by numbers of people from all over the world (from Sights, Scenes and Wonders at the World's Fair, St. Louis, Missouri, Louisiana Purchase Exposition Company, 1904).

(Text and pictures from "Heat & Cold: Mastering the Great Indoors,"
Barry Donaldson & Bernard Nagengast, ASHRAE, 1994

GARDNER T. VOORHEES, S. B.
Refrigerating Engineer and Architect.

GRADUATE OF MASSACHUSETTS INSTITUTE OF TECHNOLOGY, CLASS OF '90.
MEMBER OF THE AMERICAN SOCIETY OF MECHANICAL ENGINEERS.
BEST POSSIBLE REFERENCES GIVEN.

MECHANICAL REFRIGERATION

IN ALL ITS APPLICATIONS, AS:

Cold Storage Warehouses, Ice Factories, Street Pipe Line Refrigeration, Breweries, Factories, Hotels, Clubs, Hospitals, Office Buildings,
Theatres, Banks, Skating Rinks, Etc., Etc.

EXPERT WORK, TESTS, APPRAISING, Etc., Etc.

53 STATE STREET - [LONG DISTANCE TELEPHONE
CABLE ADDRESS "COLDMAKER"] - BOSTON, MASS., U. S. A.

(From *Ice & Refrigeration*, 1905)



Quincy Market, Boston, 1904

INVESTIGATIONS, RESEARCH, DEVELOPMENTS,
IMPROVEMENTS, COMPRESSION OR
ABSORPTION SYSTEMS

GARDNER T. VOORHEES
REFRIGERATING ENGINEER

S. B., M. I. T., '90.
MEM. AM. SOC. MECH. ENGS.
MEM. AM. SOC. REF. ENGS.

53 STATE STREET
BOSTON, MASS.

(From Ice & Refrigeration, 1919)



ALFRED WATERHOUSE
1830-1905

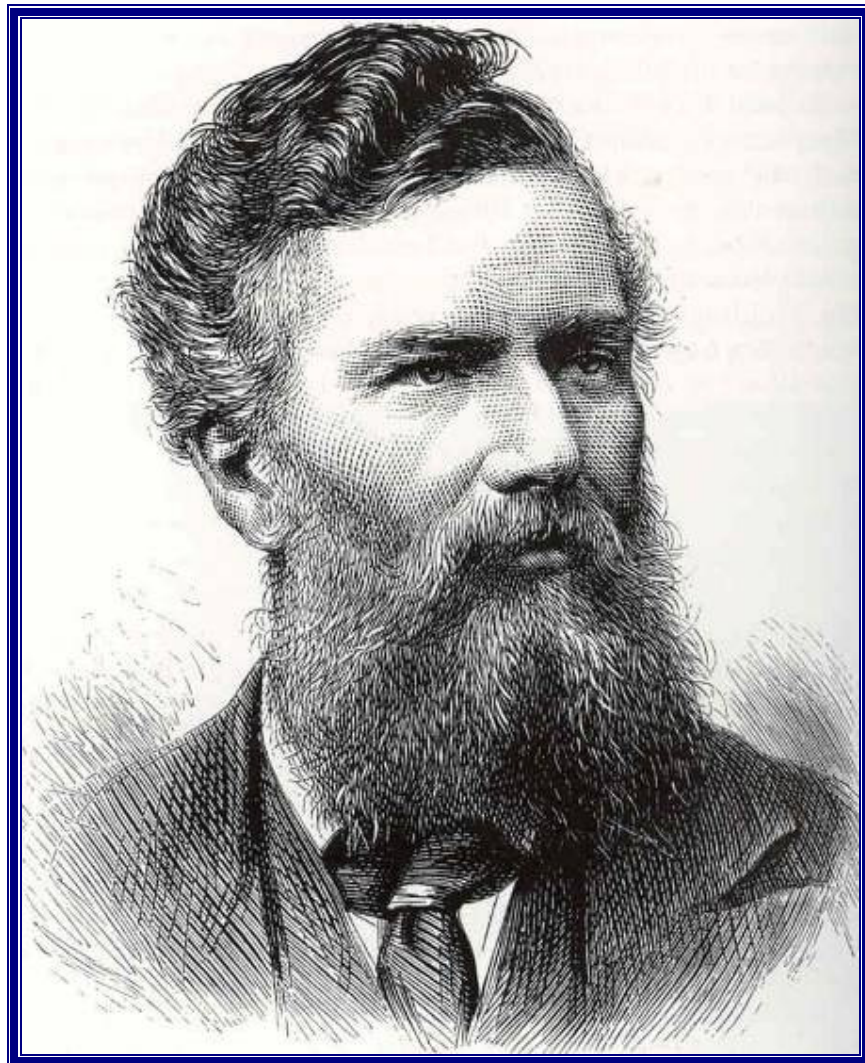

Leading English Architect

[197] Alfred WATERHOUSE

1830-1905

Leading English architect. Works include Manchester Town Hall (1877) and Manchester Assize Courts. Haden [223] recorded, "I believe the first Installation for Air Washing was put in at the Manchester Assize Courts in 1863.... The Courts were opened in the Summer, and at the first sitting the Judge complained of the heat as the weather was very hot and asked that the windows, all of which were closed, should be opened. Frederick Blake our Manager sent a note to him to say that if the windows were opened the temperature would probably rise, but the Judge asked for the windows to be opened, which was done, and the temperature went up in a very short time five degrees." Waterhouse's most famous work is London's Natural History Museum (1881), where the order for the warming and ventilation was secured by Phipson [203] in competition with Haden. Phipson's successful proposal included a surprisingly tight performance schedule, guaranteed to supply three air changes per hour, as well as balancing the humidity. In his tender analysis (1873), Waterhouse wrote that Haden did not give an estimated air change and that "they now inform me that in consequence of the Great Rise that has taken place in the cost of labour and material since they delivered their Tender, twelve months ago, they could not undertake the work except at an advance upon their tender of from 15 to 20 per cent." The ventilation scheme employed large masonry ducts under the basements, conveying cold (unheated) fresh air and warm air in a dual-duct arrangement, which could be mixed locally. (From his earlier experiences with Scott [193], Phipson had apparently learned the value of Rule No. 5). Waterhouse was also Company Architect for the Prudential Assurance Company and designed their new head office in High Holborn (1878-1906), where his association with Phipson continued. In 1886, Phipson was involved in specifying Marshal steam-driven dynamos for the electrical services with exhaust steam utilized for space heating—an early and significant example of combined heat and power. The installation was carried out by Drake and Gorham [236 and 237].

(Min-biography from "The Comfort Makers," Brian Roberts, ASHRAE, 2000)

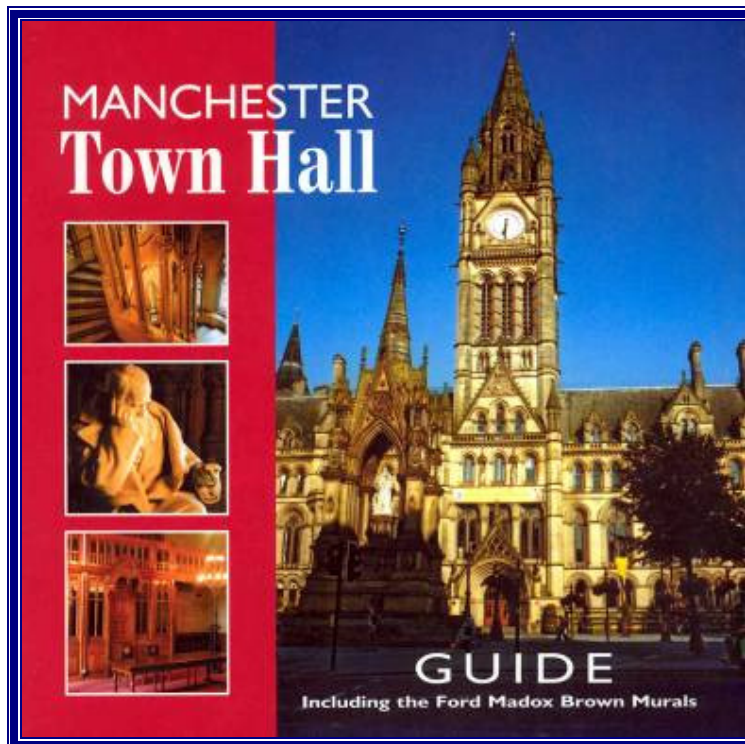

(CIBSE Heritage Group Collection)

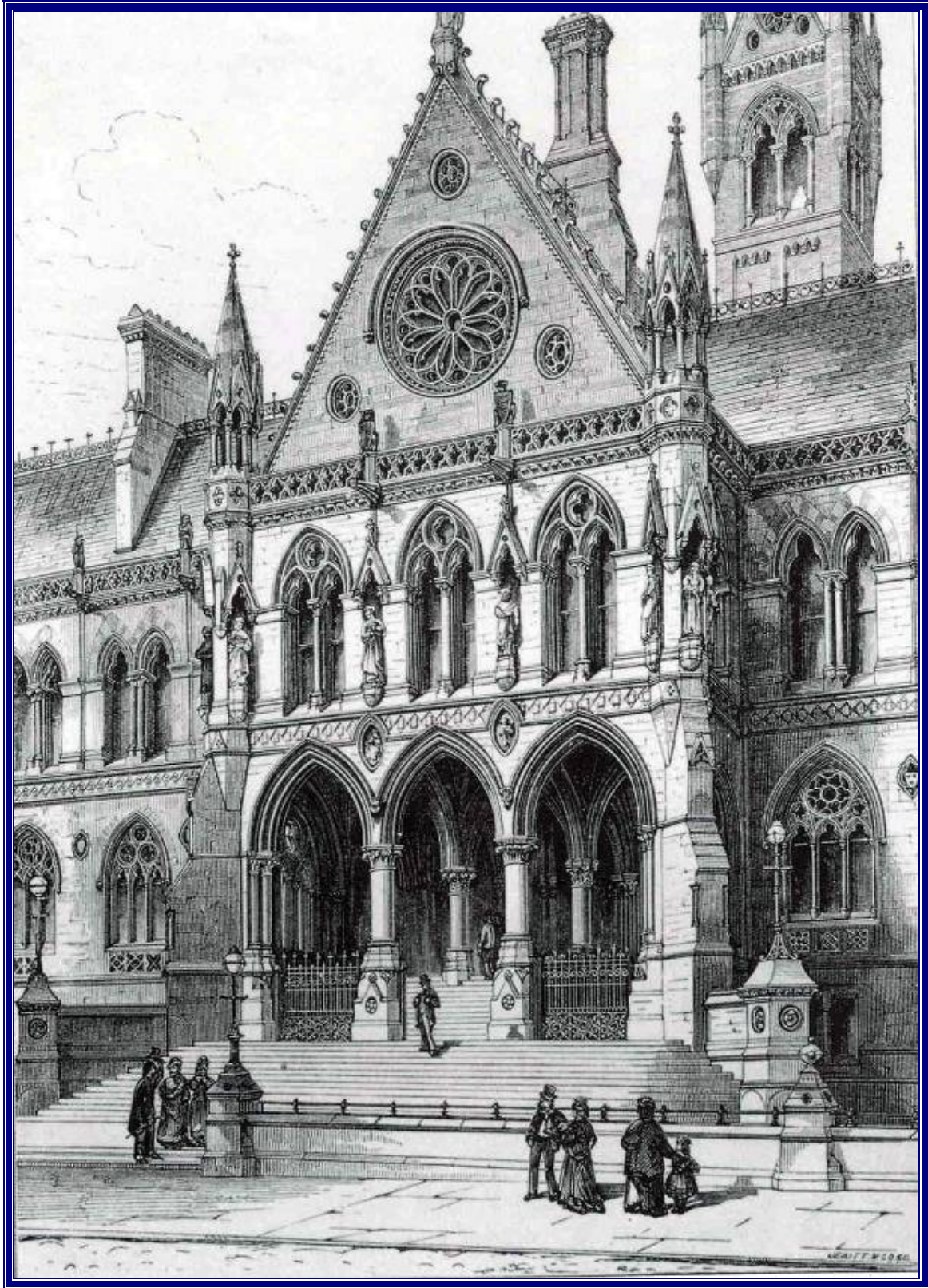

Manchester Assize Courts, 1860 (now demolished)

*Figure 4.41
HMP Manchester, Greater
Manchester. The single,
detached plenum tower.
1864–8. Alfred Waterhouse.
The extraction tower for
the heating and ventilation
system, situated between
the former male and female
prisons, is 234ft (71m)
high. [AA96/02482]*

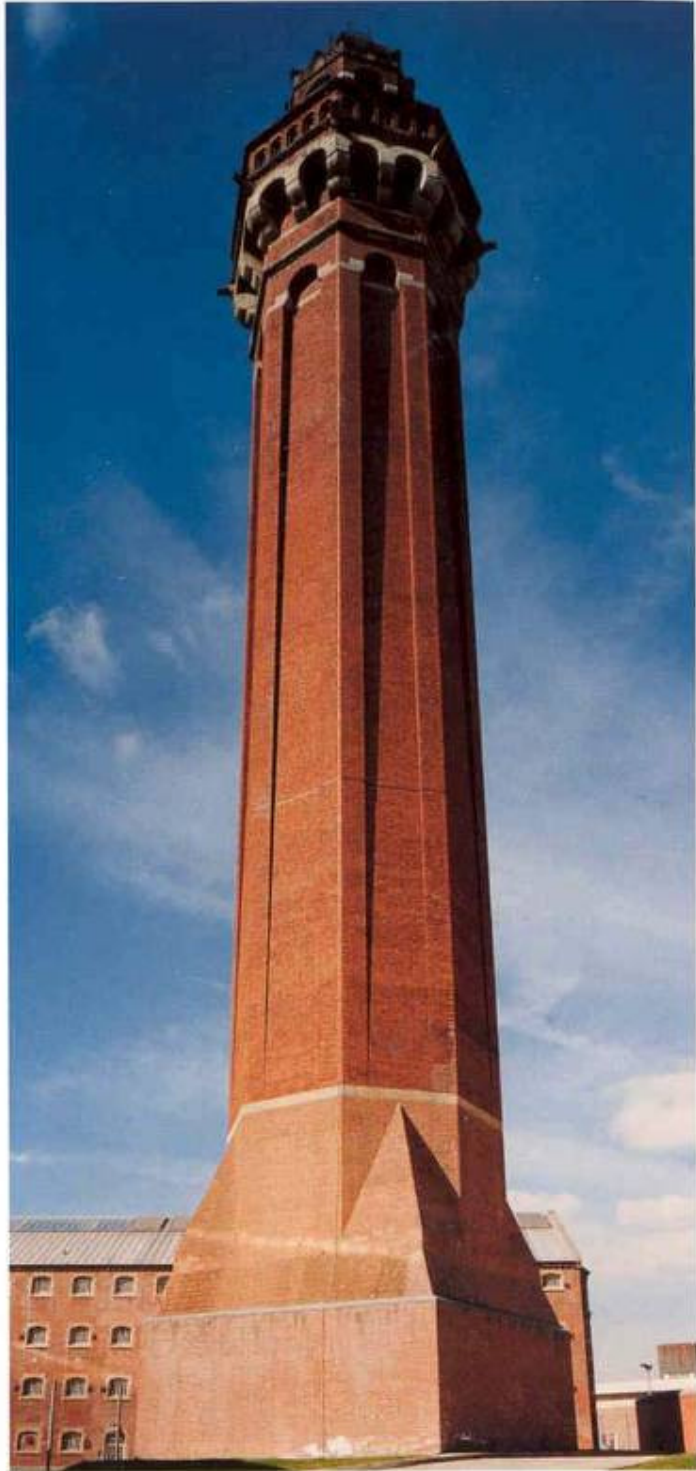

(From "English Prisons," English Heritage)

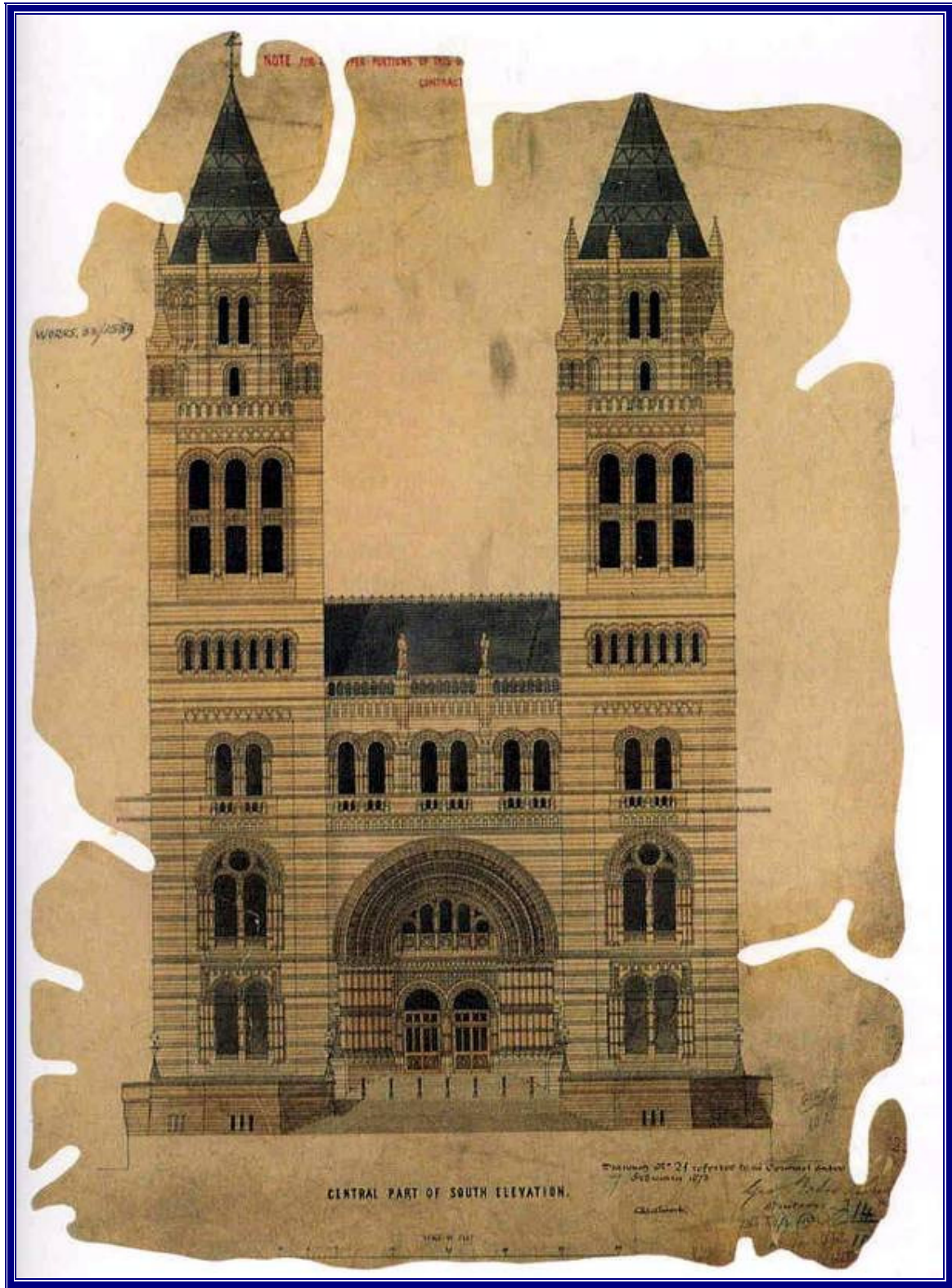

*Waterhouse's Original Design for the Central Towers, Natural History Museum
(From "Imperial London," M H Port, 1995)*

Delivering the well-tempered institution of 1873

Jeffrey Cook* and Tanis Hinchcliffe
Research in Building Group
School of Architecture & Engineering
University of Westminster
35 Marylebone Road
London NW1 5LS
United Kingdom

The Museum of Natural History, London, typified the state of environmental service design in large public buildings when construction started in 1873, as described in an earlier paper in *arq*, vol. 2. Its exemplary systems included both ventilation with heating and the architect's use of towers, especially the novel multi-sleeved versions which he described as 'thermosiphonic', as ventilation exhausts. This paper describes how, both in critical design decisions during construction and in physical adjustments made after its occupation in 1881, the Museum reveals both contemporary practices and the professional skills of its architect and engineer.

Alfred Waterhouse's design for the Museum of Natural History was innovative and informative in many ways. For example, it involved the use of a fresh air ventilation system of surprising versatility and the process of the design reveals much about the evolution of architecture and engineering as distinct professions (Cook, 1995). But design is one thing and delivery another. Even before finalising the construction contracts, Waterhouse made drastic design alterations in order to bring the building within an acceptable budget for a notoriously tight-fisted parliamentary client. The trimmed total contractual cost of £352,000 involved truncation of the south entrance towers [Fig. 1], elimination of one north smoke and ventilation tower [Fig. 2], and other reductions. But most of the economy was in substitution of materials, and it was thus that terracotta triumphed. Its choice was also justified as a cleanable surface in a coal-burning, soot-polluted city. Although there were modest changes particularly in details during construction, the environmental controls were committed by the 1873 contract. During construction, the full height of the front entrance towers was restored at the insistence of Captain Shaw, the London Fire Officer, because they contained

water tanks to pressurise fire hoses, which continue to be used today. The missing smoke and ventilation tower on the rear north-east corner was also included in the £14,000 supplementary contract that restored and enhanced the original appearance. Because of rising building costs and client changes the final museum price was £412,000 (Cunningham and Waterhouse, 1992).

The reduction of the height of the two south entry towers by 50ft (16m) was as damaging to aesthetics as it was to the service systems, where height added buoyancy for exhausting ventilation air. Together with the elimination of one of the north smoke and ventilation towers, these sacrifices allowed construction to be started. However, all the foundations and walls were constructed as originally specified so that the potential later restoration of the upper parts of the building as originally designed could be structurally sound. On 8 March 1876, Waterhouse wrote:

... these Towers (comprising the Two central ones of the Main Facade and one of the Smoke & Ventilation towers at the North end) were very considerably reduced, after the delivery of the tenders ... in order to effect a saving ...

* Visiting researcher from School of Architecture, Arizona State University, Tempe AZ 85287-1605, USA

(From Architectural Research Quarterly, Autumn 1996)

April 1998

ASHRAE JOURNAL

The magazine of the American Society of Heating, Refrigerating and Air-Conditioning Engineers, Inc.

*Ventilating
With Heating
In 1873 London*

**Thermal Storage and Deregulation
Save Energy by Trimming Pumps
Communication Gateways: Pros and Cons
Ice Storage for Campus Expansion**

Visit ASHRAE Journal Online
at www.ashrae.org

Feature Article on the Natural History Museum, London, 1873

The Architect Compares Systems and Engineers

The Public Record Office at Kew holds a document from the architect, Alfred Waterhouse, to the client "The Right Hon. The First Commissioner of H.M. Works." (PRO WORKS 18-18/3 p.15 ff)

"... Messrs. Haden propose to warm the entire building by hot water circulation from four boilers each 18 ft x 6 ft 6 in. Mr. Phipson proposes to warm the building by Hot Water too, but the water would be heated not by the boilers direct but by Steam Heaters supplied with Steam at low pressure from three boilers each 15 x 5 ft. In each case two boilers would be sufficient for performing the Work, the remaining one, in Mr. Phipson's case, or two in Messrs. Haden's, being a reserve to meet the Contingency of repairs to those in use. My impression is that one such spare boiler would suffice.

"To warm the Basement Story, Messrs. Haden propose to carry their Flow pipes under the Ceilings of the Rooms in that Story and the Return pipes under the Floors. To warm the top-lighted Galleries in the rear, they propose to place batteries of pipes under the floor, with iron Gratings above. The Front Galleries on the Ground and First floors, they propose to warm by the method adopted by them for many years past with much success, in connection with Gaols [jails], namely, by taking up Flues in the walls from the Basement and discharging warmed fresh air into the various rooms on both Stories, near the floor. To warm the Second Floor, Messrs. Haden would arrange Coils and Pedestals in the positions shown.

"Mr. Phipson keeps all his pipes in the Basement, bringing warmed air up through the walls, in the case of the front Galleries, and through the floors in the case of those in the rear. Except in the British Natural History Museum & Index Museum, in which latter place he has coils of pipes, like Messrs. Haden, under the Stairs and near the Entrance.

"Mr. Phipson Estimates that his System would renew the entire bulk of air in the various Museums, three times per hour. Messrs. Haden have not given me a corresponding Estimate with regard to the system proposed by them. The temperature to which Messrs. Haden propose to bring the Air of the Museums is 56°F and the Workshops 60°F, assuming the External Air to be 32°F. Mr. Phipson would give a maximum temperature to the Workshops of 56°F and a minimum temperature of 51°F. And the Index Museum, max: 58°F min: 52°F; Galleries, max: 60°F, min: 54°F.

"... Mr. Phipson ... has informed me that he has every reason to be satisfied that his Steam boilers are practically as safe as Hot-water boilers since they are worked at so low a pressure: and he considers them much more economical in working. He has informed me also that he could convert his System into one of ordinary Hot water Circulation, without the introduction of Steam Heaters, and reduce his Estimate to £4815, but in such case he would want a greater depth for his boilers by 2 ft. Which, in consequence of the level of the drains, I fear we could not by any possibility give him. The boiler-space is now arranged 5 ft below the level of the Basement floor and as it is, it will be only just practicable to drain it thoroughly.

"I may remind you in conclusion, that, having taken Counsel of Mr. Galton during the preparation of my drawings, I have made my plans to suit the System proposed by Mr. Phipson, as it was necessary to make them conformable to one or other of them in order to get the needful builder's work included in the Contract.

I am, Sir,
Your Obedient Servant,
Alfred Waterhouse"

This thoughtful and respectful communication by the architect Alfred Waterhouse continued throughout the eight-year construction period. Despite a low budget, high profile job with a stingy client, the mechanical engineer was always an equal if not pivotal in resolving issues. On the other side, the contractor/engineer, Mr. Phipson was equally deferent, such as his statement to the architect concerning "Escape of the Vitiated Air." "I am of the opinion that the arrangements shown on your drawings will meet all requirements." Apparently, the architect had done his job well.



LIVERPOOL
ROYAL INFIRMARY

— A HISTORY —



THE UNIVERSITY
of LIVERPOOL

Undated (CIBSE Heritage Group Collection)

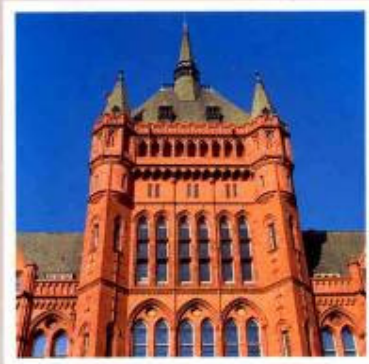

PRUDENTIAL BUILDINGS
— HOLBORN BARS —

A History and Appreciation

Undated (CIBSE Heritage Group Collection)



Prudential, High Holborn